

## in the news

### INSIDE

MIT introduces a new low-cost dormitory theft insurance plan for both undergraduate and graduate students.

p3

The varsity soccer team holds defending Division III national champion Babson scoreless for 60 minutes before succumbing, 2-0, in a hard-fought game at Briggs Field.

p8

Cross-country, paced by senior All-American Frank Richardson's course record, wins the Engineers' Cup over WPI and RPI; the rugby 'B' squad edges Coast Guard's 'A' team, 17-16.

p8

### OUTSIDE

Jimmy Carter's worst obstacle in his campaign for the presidency may be his not-too-infrequent slips of the tongue, observes *The Tech* columnist William Lasser. This issue, *Political Spectrum* offers an analysis of how the first debates have affected the candidates' election prospects.

Boston police and school officials have reinstated heavy security procedures, including extra patrol officers and metal detectors at the door, at Hyde Park High School following a serious racial disturbance in front of the school Friday morning in which seven persons were hurt and eleven arrested. It was the most serious flareup thus far at Boston schools since classes began September 8.

The Watergate special prosecutor's office is investigating allegations that President Ford, while a Michigan congressman, illegally used campaign contributions for personal business. While authoritative government sources termed the allegations "serious" and "significant," they said no conclusions have yet been reached as to the President's involvement in such an episode.

## ASA rejects SACC movie appeal

By Glenn Brownstein

The Lecture Series Committee (LSC) is the only MIT student organization authorized to show a weekend entertainment film series, the Association of Student Activities (ASA) reaffirmed at a general meeting Sunday night.

By a vote of 28-11 with four abstentions, the ASA upheld its Executive Committee ruling of two weeks ago, which stated that the Social Action Coordinating Committee (SACC) could show the first three movies of its Friday night film series, with LSC approval required for further showings.

As of today, LSC had unofficially indicated that "To Kill a Mockingbird," "On the Waterfront," "Citizen Kane," and "Hail to the Chief" would likely be approved for SACC showing.

SACC film spokesman Alfred Geller '79 said that the left-wing political organization would appeal Sunday's decision to the General Assembly (GA) on the grounds that the ASA representative base is very limited and "not representative of the desires and interests of the vast majority of the students on the MIT campus."

Geller also remarked that SACC would begin a petition drive to gain signatures of students supporting its position, in the belief that it "would show students believe we should be al-

lowed to exist and that the GA and ASA should reflect the desires of students." Such a petition would be presented at the GA appeal meeting.

Both sides largely rehashed previous arguments during the two-hour meeting, with SACC claiming that it believed the campus market could support two film series and that LSC did not provide an essential or unique service that would merit exclusive rights.

Undergraduate Association President Phil Moore '77, who did much of the debating for SACC, expressed the political organization's belief that although the markets for the two film series overlapped, they were not alike. He also explained that SACC needed operating funds over and above Finboard's \$38 budget (not counting a \$120 fund earmarked specifically for "educational activities") and that it wanted to sponsor politically and socially thought-provoking movies on campus.

LSC argued that while it did not object to a significantly different film series, it believed that the community could not support two similar groups, or, more importantly, three or four. Len Tower '71, one of three LSC spokesmen, explained that he felt that although the existing market would probably expand to one-half of the needed "no effect on either group" capacity, and LSC

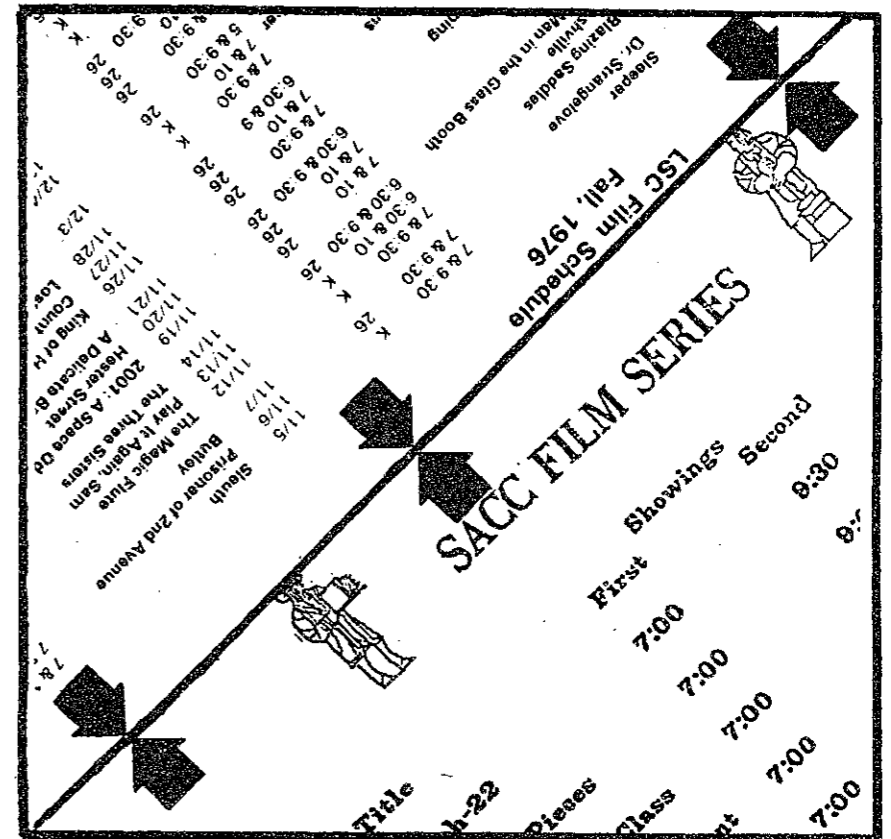

probably could afford just SACC as competition, in the long run, the presence of other groups would severely hurt LSC.

After a brief debate between the conflicting groups and a question-and-answer session with ASA members, the vote to uphold or overturn (or modify) the earlier ExecComm decision was taken, with LSC winning by a substantial margin. Although 43 votes were recorded, some individuals, representing more than one group, voted a number of times.

Through the first two weeks of

competition, SACC has reported near-overflow audiences (capacity 600) as opposed to LSC's lower-than-expected attendance. SACC's film discussions after its second show have been poorly attended, as no one stayed for the first, after "Catch-22," and only eight members of the audience participated in the "Five Easy Pieces" discussion.

SACC's appeal to the GA is expected to be the final step in the resolution of the conflict with LSC. No date for the meeting has yet been announced.

## Northgate properties to be divested

By Drew Blakeman

Although the Northgate apartments are not the severe economic liability that they were a year ago, MIT officials still plan to divest the Institute of these properties as soon as possible.

Northgate is a series of eight apartment buildings in Cambridge and Somerville which were originally purchased by the Institute to fill the off-campus housing need of MIT students, faculty, and other employees.

Initially, however, the apartments were financially unprofitable. Many of the buildings were in poor physical condition, driving away prospective tenants and lowering the occupancy rate. Vice President and Dean of the Graduate School Kenneth Wadleigh '43 told *The Tech* last year.

Half of the original buildings had been sold by MIT as of last October, according to Wadleigh. Records of the Off-campus Housing Office show that four more have been sold since then, resulting in a reduction in the number of vacancies. Only one apartment out of the more than two hundred in the entire project is now vacant.

Charles D. O'Neal Jr., Administrator of the Northgate Community Corporation, says he has "no idea" when the remaining properties will be sold. When a reporter asked, he said, "You're the twelfth person who wants to know. The other eleven are the Board of Directors of Northgate."

The Northgate Community Corporation has complete ownership and control of the Northgate properties. This corporation, in turn, is totally under

the control of MIT. Ten of Northgate's directors are MIT administrators, while the eleventh is a lawyer who does legal work for the Institute.

"We have had serious offers on a number of the properties," O'Neal said, but they were turned down as unrealistically low. "We are out to make a profit. We don't want to give the properties away."

Two buildings in Somerville are leased by the Northgate corporation. The leases on both buildings expire in three years, and according to O'Neal, Northgate will not renew those contracts. Two buildings in Cambridge are on long-term leases, and three in

Cambridge are owned outright by Northgate.

A fourth Northgate property, Random Hall, is currently a rooming house. Originally built as an MIT dormitory, the Institute sold the building to Northgate when it was felt it was no longer needed. With the current housing crunch, according to O'Neal MIT has been considering purchasing Random Hall to help alleviate dormitory overcrowding. Because of the complexity of the law, the Institute would be forced to buy the property from Northgate even though it already owns the building indirectly.

O'Neal said that no one is cur-

rently prepared to take over the properties, "but the situation could change within the next five minutes." He said that Northgate is willing to wait the three years until the leases expire on the two Somerville properties, but hopes to find someone willing to take over the leases on the long-term holdings as well as purchase the other buildings.

The Northgate Corporation tries to "respond more adequately to the needs of the tenants," according to O'Neal, who said that Northgate complaints are looked into and problems resolved sooner than by most other landlords. He added that the rent is "a little lower" for the Northgate apartments than for similar apartments elsewhere. "There were no rent increases last year except in one of the buildings, and that was only a two-and-a-half percent increase," O'Neal noted.

When MIT eventually does divest itself of the Northgate properties, there should be no problems for the current tenants, O'Neal stated. "The tenants will be protected for as long as their leases are in effect." Even then, he added, people who want to remain in their apartments should be able to. "Apartment owners don't like vacancies."

Approximately half of MIT's students, both graduate and undergraduate, live in non-Institute housing. Of these, about ten percent live in Northgate apartments. The other Northgate residents consist primarily of MIT faculty and other employees. There are a few residents who are not a part of the MIT community, but they are mostly holdover tenants who occupied the buildings when the Institute acquired them.



MIT's Northgate holdings include this set of apartment buildings on Mass. Ave. in Cambridge, as well as Random Hall.

Corey Chaplin

# notes

\* Anyone interested in forming an Archery Club for practice, competition, etc., should contact Chris Reiser, 410B Ashdown, x5-9776.

\* Raja and Radha Reddy will perform classical Indian dances on Saturday, Oct. 2 at 7:30pm in Kresge Auditorium. Tickets to the performance, sponsored by Sangam, the Indian student club, are \$6, \$4, and \$3 with student seats \$1 less. For reservations, call 494-8928 between 7 and 10pm.

\* There are still a few openings in the 6S09 seminar, involving communication equipment design and construction. Interested students may contact either the Undergraduate Seminar Office or C.D. Paton, Room 9-370, x3-7411.

\* The MIT Concert Band is sponsoring a tour of the Soviet Union and Czechoslovakia over this IAP, January 5 to 25, 1977. Stops include Moscow, Leningrad, Kiev, and

Prague. Cost is \$1275 per person, all inclusive. The tour is open to all members of the MIT community, but space is limited. Send for brochure now: Concert Band Russia Tour, Room W16-002; or call x3-2906.

\* Ralph Nader and Sam Lovejoy will highlight a day of films, workshops and speeches at Boston University Thursday, Oct. 7. The dangers of nuclear power will be featured in films shown at Sherman Student Union beginning at noon. Nader and no-nukes activist Lovejoy will speak at Morse Auditorium beginning at 3:30.

\* The Cambridge YWCA plans a New Hampshire foliage trip, Saturday, Oct. 2, featuring a tour of the scenic, 34 1/2 mile long Kancamagus Highway. The tour, which is open to men and women of all ages, leaves at 9am and will return early the same evening. Anyone interested should call the YWCA at 491-6050.

## classified advertising

**Help Wanted.** casual wiring small electronic circuit boards. Les. 277-4358.

**JOBS!** Expanding Corp. has immediate openings Starting take home pay, part time \$60 a week — 15-20 hours; full time \$150 a week. Flexible hours, scholarship money available. For interview call Monday-Friday 9-5, 396-8773.

**Classes in Early Musical Instruments.** Viol Making with Warnock. Harpsichord Maintenance with Dowd. Take Viol Lessons with Jeppesen. For further information contact Musical Instruments Collection, or call 267-9... ext 430.

**1970 Honda 350.** 9500 miles. Motor very good, body fair. Sell now. \$399. Al. 354-1222. Best in evs, but try anytime

**Space Colonists Sought.** Resume: Education, skills, reason for migrating. Estimated departure date 1985. Pioneer Situation. Space Travel and Astronautic Research Society, P.O. Box 652. Alhambra, California 91802.

**For Sale:** 1" uncoiled paper tape .50/roll. Labeling attachment with supply of gummed tapes for Pitney Bowes DM-3 Postage Meter \$5 Air Mattress \$10 **Wanted:** 1 or 7/8" oiled paper tape. Call Len, x3-1541

**The Tech Classified Ads Work!** \$3.00 per 35 words (or less) the first time. \$2.25 each time after that, if ordered at the same time. Just send your ad with payment to The Tech, W20-483 or PO Box 29, MIT Branch, Cambridge, MA 02139 by US Mail!

**Men's 10 speed Bike.** Damaged frame. Can be repaired. Best offer. x5-7262 evs.

Available immediately: full and part time positions for **XEROX Operators** (all shifts, including midnight to 8am) Contact Eddie Shaoul, weekdays 2-4pm, 99 Mt. Auburn St., Cambridge. Call C-O-U-R-I-E-R.

Right now, up until Oct. 31st, you can fly roundtrip from New York to Luxembourg for only \$360.

That's \$106 less than the youth fare you'd pay on any other scheduled airline. (From Chicago you pay \$401 and save \$113.) All you have to do is be under the age of 24.

There are no booking restrictions. And no skimping on meals or service. Because we give you the same service you'd get from other airlines, without the same high costs. So, if you're planning on Europe, fly with us on Icelandic. We'll give you more than the lowest youth fares.

We'll give you the best deal.

See your travel agent or write to Icelandic Airlines Dept. # CN, 630 Fifth Avenue, NY, NY 10020. Or call toll free (800) 555-1212. Fares subject to change.

**Save \$106 on jet fares to Europe and book anytime you want.**

**Icelandic**  
LOWEST JET FARES TO EUROPE OF ANY SCHEDULED AIRLINE.

### CENTRAL WAR SURPLUS

433 MASS. AVE., CENTRAL SQ.

Trowbridge 6-8512

Everything For the Sportsman, Skier, Camper, and Outdoorsman

AT LOWEST PRICES

Headquarters for Levi's and Lee's

### FOREIGN LANGUAGES TRANSLATION

Translators in all languages for part-time on call work.

Send details to: P.O. Box 54 Cambridge, Mass. 02138

### Sangam presents

An Evening of Indian Classical Dance

Raja and Radha Reddy

Bhaskar and Cindy



Saturday, October 2nd.

7:30 P.M.

Kresge Auditorium

Tickets \$6, 4, 3

Students \$1 off

All seats reserved.

For reservations:

call 494-8928

between 7 and 10 P.M.

choose one of the following:



**John Paul Jones was**

- (a) a merchantman engaged in American and West Indian trade.
- (b) a scotsman.
- (c) a Rear Admiral in the Russian Navy.
- (d) all of the above.
- (e) none of the above.

We all know that Jones was a great Naval hero during the Revolutionary War, but if you chose (d), you are correct. Jones led a rich, and varied life. Are you surprised? There are many things about the Navy that would surprise you. NROTC at MIT is one. Why don't you come in (Room 20E-125) or give us a call at 3-2991.

You may be pleasantly surprised!

**We want men and women with engineering or other technical degrees**

... for careers in steel operations, shipbuilding, engineering, sales, mining, and research. Opportunities for accounting graduates, too.

Our Loop Course recruiters will be here on

**OCT. 15, 1976**



Let's talk about it.

**The Loop's the way**

**Bethlehem**



an equal opportunity employer



# The master control room: television and its impact

By Glenn Brownstein

It is entirely appropriate that the most notable aspect of Thursday's Ford-Carter presidential debate may have been the 28-minute audio loss during the telecast, not anything either candidate said.

We are all used to candidates, for any office, hemming and hawing around key issues during a campaign. The hopefuls who make the specific promises don't always win — these promises have cost them various valuable segments of their normal constituency — and those that do are usually severely chastised when the campaign promises are not kept, when the new office-holder discovers that the present bureaucracy he has taken over won't permit him to keep them.

More importantly, what we are used to now, and were not, say 20 years ago, is the incredible impact of television. The minute or so that Jimmy Carter spoke while the sound was out was heard by maybe 500 people. His words were not any less important, but the lack of audio made them less so. A more far-reaching example is that of the just-past presidential nomination campaign, in which television, consciously or otherwise, dictated which candidates received the most publicity or exposure, and enhanced (or limited) the chances for every Democratic and Republican hopeful.

Television's role has grown ever since a Columbia-Princeton baseball telecast nearly forty years ago. From Edward R. Murrow's courageous stand against McCarthyism 23 years ago to televised Watergate hearings, the medium has shaped American and world opinion. It has dictated football, baseball, and basketball scheduling; it has reduced the distance between the coastlines on one hand, and between the newsmakers and the "average American" on the other. It lends importance to happenings simply by "being there," and even, in the opinion of some, instigates violence by the presence of cameras waiting to record it.

Those Americans who spent childhoods and adulthoods listening to the radio now find their children, and themselves, spending endless hours in front of the "boob tube" — the average set is turned on six hours each day and the average viewer watches nearly three hours daily. What ex-Federal Communications Commission Chairman Newton Minow once termed a "vast wasteland" is still a very captivating entertainment medium. There are very few complaints when a debate is preempted by "The Mary Tyler Moore Show," although the reverse policy can prompt hundreds of viewer complaints. CBS refused to show Senate Foreign Relations Committee hearings 15 years ago, preferring to stick with "I Love Lucy" reruns; that decision caused the resignation of Fred Friendly, producer of the Murrow-McCarthy telecasts, as well as the "See It Now," "Person to Person," "You Are There," and "CBS Reports" series.

While newspapers continue to fold and consolidate, while radio stations, except for a select few, offer varying types of music or news programming, television continues to grow and become more powerful. Voting projections in the East on Election Day may well determine the degree of voting in the West, when the Carter-Ford battle reaches its climax. Clearly television has made a serious impact, both on the viewer and on every important happening in this country. It may determine our next President, just as it helped elect John F. Kennedy in 1960 (radio listeners believed Nixon had won those debates, although TV watchers clearly chose Kennedy).

What may we expect from television in the future? I'll examine that in a later column.

Mike Peters

CHARLES DODD



"SOUNDS SUPER SWEETHEART, BUT WE'RE GETTING SOME FEEDBACK FROM YOUR CHEST MIKE... TRY WORKING THE BOOM A LITTLE MORE... AND PICK UP THE PACE WE DON'T WANT TO RUN INTO KOJAK..... OTHERWISE FAT CITY....."

## feedback

### LSC audience courtesy lacking

To the Editor:

Many will read this and ask, "What do you want for seventy-five cents?"

Anyone who ever sat through an LSC movie will know immediately what I'm talking about; i.e., the very rude and childish habit which so many regulars have adopted of making their own "personal statements" by whistling, hooting, and applauding at what many of us consider to be the most inappropriate times. Since there is at least an equal number of people shushing those who whistle and applaud, I wish to speak for those who are either irritated or enraged by such repeated interruptions.

On Saturday night *The Exorcist* was shown to an enthusiastic and oddly appreciative audience. On numerous occasions the dialogue was completely drowned out by those who felt it necessary to make their own comment on: the efficacy of brain surgeons and psychiatrists, the Catholic church, a certain neighboring university, authority figures in general, and student revolutions and administrative reactions to them. As usual, such frequent outbursts made it difficult for viewers even to follow the story line. A student in front of me had to ask his friend in the next seat about the identity of the first victim! "Who is Burke Denning?"

Popular opinion may be that these LSC movies are not first-run and that the great majority of people in attendance have already seen the movies. Why, then, is it necessary to hear the dialogue when everyone already knows what is going on? Aside from the fact that there will most certainly always be some who are seeing the film for the first time, consider this very brief list: *Nashville*, *A Man for All Seasons*, and *Sleuth*. Certainly, these critically acclaimed movies must have been seen at one time or another by most people at the Institute. Who among them would dispute the benefit of hearing again (and again) the dialogue that distinguishes these movies from mediocre pulp?

This brings me to my major concern and the reason for my

tirade: How will MIT react to this semester's Sunday series if they hold the best of America's film-makers in such contempt?

Let me first express my gratitude to LSC for choosing the best of the American Film Theatre. These theatrical contributions to our film-oriented society are noteworthy and deserving of an appreciative audience. But if audience reaction to *The Man in the Glass Booth* is any indication of what we have to look forward to during the remaining offerings, I am sorely disappointed.

It was insulting (not to mention maddening) to have to put up with the standard jeering that followed, the mere mention of Harvard University in the dialogue. And those who chose to hoot and stomp at subtle intimation and revealing characterization proved

only that they, in their ignorance, had no conception of what was going on in the film. If this paranoid reaction is to be the rule at each of the Sunday movies, I am concerned for the success of LSC's noble undertaking; and I suspect that MIT's audience will prove true what the Ely Landau organization must have feared when they limited viewing by subscription orders. That is, that the "common man" is not prepared to give his full attention even to the most deserving playwrights of our day, and that a truly ordinary audience will not rise to the intellectual challenge of subtle characterization and word play. Mel Brooks — bless him for his own genius — has done his worst, and the Three Stooges reign supreme.

I do not fault an audience's joyful reaction to real humor, whether it be in *Blazing Saddles* or *Play It Again, Sam* or *Sleuth* or any other in the long list of comedies we have to choose from. We all go to the movies, in part, to escape; to get away from problem sets or problems, in general. But one can "escape" into a simple melodrama, or a mystery, or a musical as well. It is not necessary to make every movie we see a private and personal comedy by interposing our own prejudices and dislikes into the dialogue. Can't we recognize that movies are not necessarily produced with the purpose of giving MIT students an opportunity to vent their hostilities? Will not a quiet chuckle suffice when we find a particular allusion amusing, or even ludicrous?

If you want to express your personal disdain for particular institutions, or other people's beliefs, or the world situation, or whatever, can you truly think that the most appropriate way is to make an anonymous catcall in a darkened theater? Surely, there must be a better way to make your statement. If not, of what value is your statement anyway?

What do I want for seventy-five cents? I want seventy-five cents worth of common courtesy. It will go a long, long way.

Karen E. Kofe  
September 26, 1976

## The Tech

Julia A. Malakie '77 — **Chairperson**  
Glenn R. Brownstein '77 — **Editor-in-Chief**  
Mark J. Munkacsy '78 — **Managing Editor**  
John M. Sallay '78 — **Business Manager**

Volume 96, Number 33  
Tuesday, September 28, 1976

### NEWS DEPARTMENT

**News Editor:** Gerald Radack '77; **Staff:** Donna Bielinski '80, Drew Blakeman '80, Jeanne Brady '78, Peter Coffee '79, James Eisen '77, Henry Fiorentini '79, Katy Gropp '80, Mark James '78, William Lasser '78, Hillary Lust '80, Eileen Mannix '79, Daniel Nathan '79, Rich Newcome '79, Nivin Pei '79, Kent Pitman '80, Thomas Spisak, Paul Yen '80, **Staff Candidates:** Stephen Besen '80, Kate Mulroney '80, Pat Thompson '80, Stephen Utkus '79, Bob Wasserman '80.

### PRODUCTION DEPARTMENT

**Night Editors:** David Thompson '78, Rebecca Waring '79; **Production Manager:** Lynn Yamada '78; **Associate Night Editor:** Kevin Wiggers '79; **Staff:** Bill Pritchard '78, John Guppy '79, Richard Lamson, Pat Thompson '80; **Staff Candidates:** Steve Frann '80, Brad Miller '80, Barry Newman '80.

### PHOTOGRAPHY DEPARTMENT

**Photo Editors:** Tom Klimowicz '77, David Schaller '78; **Associate Photo Editors:** Mark James '78, Richard Reihl '78; **Staff:** Mike Garcia '78, Rob Mitchell '78, Corey Chaplin '79, Randy Fahey '79, Gordon Haff '79, John Hopper '79, Lee Lindquist '79, Dave Martin '79. **Staff Candidate:** Claude Perry '80.

### SPORTS DEPARTMENT

**Sports Editor:** Deborah August '79; **Staff:** Jay Morris '76, Leo Bonnell '77, Dave Dobos '77, Chris Donnelly '77, Charles Cox '79.

### BUSINESS DEPARTMENT

**Acting Advertising Manager:** Martin Weinstock '78; **Associate Business Managers:** Steve Kirsch '78, Margot Tsakonias '79; **Accounts Receivable:** Marcia Grabow '79, Brenda Hambleton '79; **Accounts Payable:** Jeff Singer '77; **Advertising Staff:** Thomas Athanasas '77, Peter Balbus '79, Jay Petersen '80; **Circulation Manager:** Ron Parton '79; **Circulation Staff:** Brian Rehrig '75, Jim Large '80, John Love '80.

Third Class postage paid at Boston, MA. *The Tech* is published twice a week during the academic year (except during MIT vacations) and once during the last week of July. Please send all correspondence to: P.O. Box 29, MIT Branch, Cambridge, MA 02139. Offices at Room W20-483, 84 Massachusetts Avenue, Cambridge, MA. Telephone: (617) 253-1541. Advertising and subscription rates available on request.

LSC presents:

The Sound and the Fury

starring Yul Brynner

and Joanne Woodward

vs. the MIT Audience

# opinion cont.

Political Spectrum

## Carter's campaign errors

By William Lasser

Jimmy Carter is doing very well lately in his quest to become the underdog in the presidential campaign this year. While he may lose the election, the former Georgia governor stands a fine chance of winning the George S. McGovern "I'm behind him 1000%" award for the stupidest campaign statement of the year.

Carter's qualifications on this last score are numerous. As if "ethnic purity" were not bad enough, he has topped that blunder by first granting an interview to *Playboy* magazine, and then making statements which do not bely a candidate for anything, much less President of the United States.

*Playboy* is a periodical which has lost all legitimacy by appealing to what some like to call "prurient interests." It was not always thus. In recent years, due to strong competition from similar magazines, *Playboy* has abandoned its attempt to include articles and interviews of importance along with the pictures, and has become a monthly journal of sex.

Surely Carter, or someone on his staff, knew this. *Playboy* is most concerned with selling magazines to a specific audience. Interviews in *Playboy* emphasize those qualities which are exactly opposite to the ones a candidate is likely to want publicized. Nevertheless, Carter agreed to be questioned.

One would think that under such circumstances a candidate would be very careful about what he said. Carter was not. He announced that he had committed "adultery in his heart" — a very easily misinterpreted statement which applied, it seems now, only to his religious beliefs, but which caused great damage anyway.

He said the words "screwed around" — an expression which the *New York Times* termed a "vulgarism" and refused to print. And perhaps worst of all he accused the late President Lyndon B. Johnson of "lying, cheating and distorting the truth," a charge which, regardless of its validity, does not sit well with voters in Texas, a crucial state.

These are but the latest in a series of errors which have marked the Carter candidacy. He said that he would raise taxes for all those who make over the median income, then later corrected

himself and announced that he would never "raise the taxes of working people."

Carter has apologized for or tried to explain away all of these and many more misstatements. But American politics is a science of impressions — one can never be sure that a retraction will reach all the people who saw or heard the original statement, nor can one be assured that all will accept the correction.

I do not criticize Carter for what he has said — I personally believe that the remarks were made under conditions of stress and I accept the retractions. But I must be concerned with the whole style of the Carter candidacy — mistake after mistake followed by apology after apology. Such strategies do not win presidential elections.

In playing Gerald Ford to a draw in the first debate Carter has stemmed the tide of the President's momentum. After a very shaky opening, Carter seized the initiative on the amnesty-pardon question and clearly bested the President on energy policy. The President's slim victory, as shown by the post-debate polls, was due to viewers who saw only the beginning of the debate, for in the end Carter was the clear winner.

Carter also gained by just appearing on the same platform as the President of the United States. He increased his national standing

by showing that he could in fact argue as well as Mr. Ford. Experts agree that while the debate did not change the minds of many voters, each candidate firmed up his own support. That should be enough, if the trend continues, to bring victory to the Democrats in November.

But Carter is prone to mistakes and ill-considered declarations. He does not think before he speaks. He seems to lack an intuition about national politics. It is a matter of experience. In response to questions about the *Playboy* interview, Carter said, "I think this frankness might very well not be a good, safe thing to do in a political campaign."

The presidential campaign trail is not the place to learn the ways of American politics. Slowly, Jimmy Carter is beginning to understand how the country works. It isn't an easy education.

## ARABIC

small conversation group for beginners organized by Academia. Course will start on October 5. Telephone 354-6110.

## ARMY ROTC at MIT

In the Class of '76, 13 graduates were commissioned in the US Army in the following branches:

- 6 Corps of Engineers
- 3 Signal Corps
- 1 Medical Corps
- 1 Medical Service Corps
- 1 Military Intelligence
- 1 Ordnance Corps

Individual honors included:

- 9 Distinguished Military Graduates
- 1 Medical School Scholarship Winner
- 2 Army Fellowship Winners

The Army has a continuing need for leaders of this quality. If you are interested, contact Captain Murphy in 20E-126, or call him at 3-4471.

## Psychiatric

### Counseling

### For College

### Age Adults

COLLEGE MENTAL HEALTH CENTER

Located in Prudential Center. For information call 262-3315.

Nº 1200

# JAZZ

The Undergraduate Association presents

## THE JOHN PAYNE BAND and MISTRAL with Randy Roos

In Concert Friday, Oct. 1

8:00 p.m. in Kresge Auditorium

Tickets \$2<sup>00</sup> — No Reserved Seats

For group discount and advance sales contact U.A. Office

## Mass. auto insurance, explained.

Mass. automobile insurance can get a little complicated. And if you're under 25, it can get expensive. We'll simplify things. And we'll help you keep your premiums as low as possible.

### W. T. Phelan & Co.

Insurance Agency, Inc.

11 Dunster St., Harvard Square (next to the Holyoke Center). 876-0876. Representing Aetna, Travelers, Hartford.

## Ready for Recruiting?

The Career Planning and Placement Office invites you to a seminar:

### Your Job Search: How an Employer Evaluates You

Albert C. Dierckes, Jr. '60  
Section Head  
Paper Products Development  
The Procter & Gamble Co.

Thursday, September 30, 1976  
3:00 p.m. Bush Room, 10-105

## Graduate Research Assistantships In Civil Engineering

The Department of Civil Engineering at Princeton University invites applications for graduate study and research in the areas of Structures and Mechanics, Transportation, and Water Resources leading to M.S.E. and Ph.D. degrees. Annual research stipends start at \$4,240 plus tuition and are offered to all admitted students requesting support. For details and applications write:

Professor Peter Lee  
Director of Graduate Studies  
Department of Civil Engineering  
Princeton University  
Princeton, N.J. 08540

## TheTech

Are People (parents, spouses, children) at home always asking you about what happened at MIT lately? Why not let them find out for themselves in *The Tech*. Have a copy of each issue mailed home to keep them up to date on MIT. Just fill in the coupon below and send it in with your payment to start your subscription today.

Keep up with what's going on at MIT

Have *The Tech* mailed to your home

### SUBSCRIPTION RATES

28 Sept 76

Send with payment to  
Circulation Manager  
*The Tech*  
PO Box 29 - MIT Br.  
Cambridge, MA 02139  
(W20-483 by Institute Mail)

Renewal: Yes  No   
US Mail - 1st Class 1 yr \$16  2 yrs \$31   
3rd Class 1 yr \$6  2 yrs \$11   
Foreign - Air Mail 1 year \$90   
Surface Mail 1 year \$16   
Institute Mail - 1 yr \$4  2 yrs \$7

Name \_\_\_\_\_  
Address \_\_\_\_\_  
City \_\_\_\_\_ State \_\_\_\_\_ Zip Code \_\_\_\_\_

# Tech Hifi's Midnight Madness Sale!

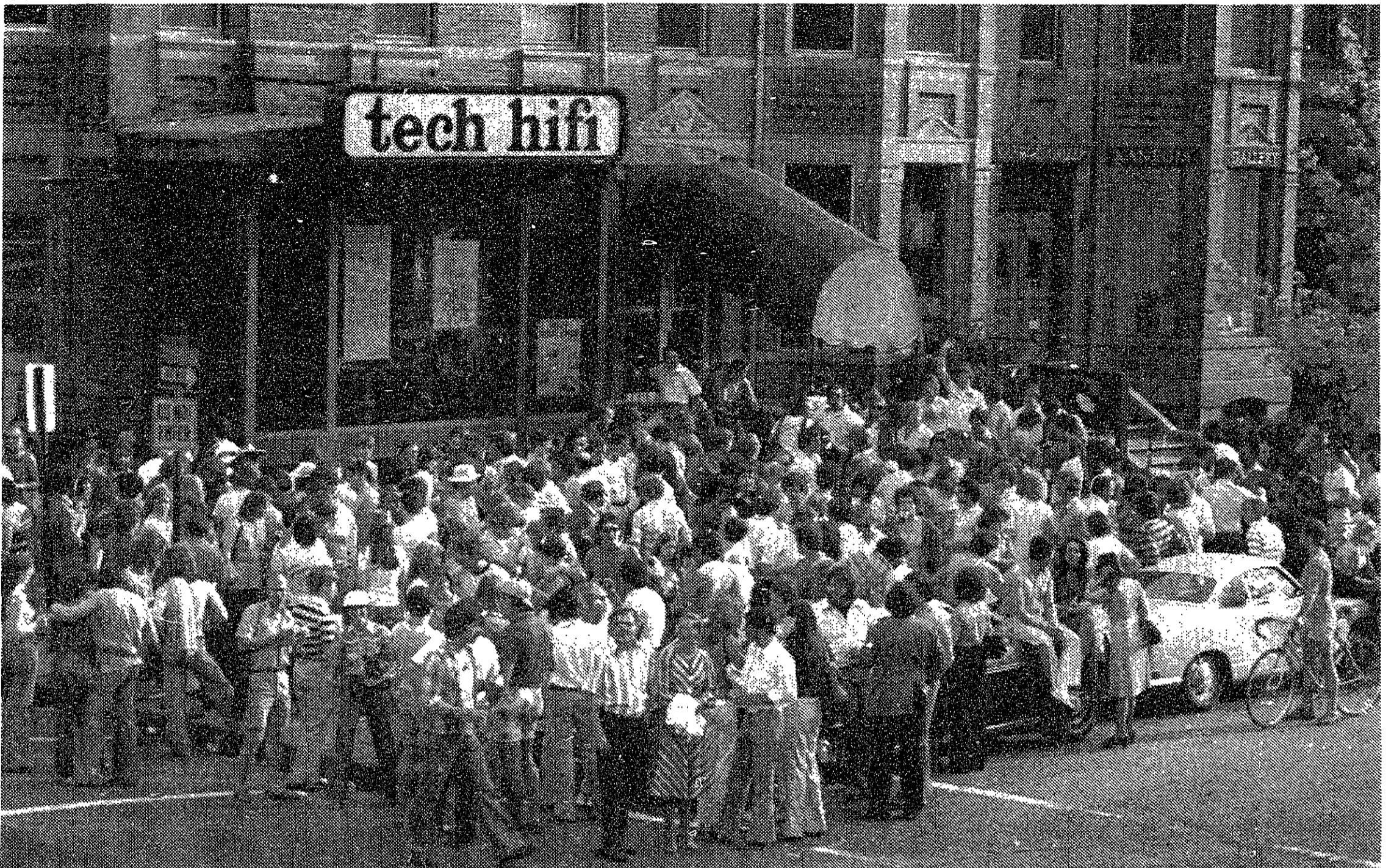

**Come early and avoid the maddening crowd.**

Once in a while, Tech Hifi goes mad. We sell our demonstrator units below cost, and we price new stereo components so low we'd be crazy to do this sort of thing too often. So don't miss the rare Midnight Madness of Tech Hifi. We begin to go berserk on Monday, and the final frenzy will go until Thursday, September 30, when the Tech stores listed below will stay open until Midnight! Here is some proof of our temporary insanity:

**Complete Systems**

Concord CR50 receiver, KLH 100 loudspeakers, BSR 2260, ADC cartridge: for \$199!

KLH 71 receiver, Studio Design 26 loudspeakers, BSR 2260BX turntable, ADC cartridge: \$239

Technics 5060 receiver, ADC XT-6 loudspeakers, Gar-

rard 440M turntable Pickering cartridge: for \$279 this week!

Marantz 2215B receiver, Centura IVa loudspeakers, Garrard 440M turntable, Pickering cartridge: only \$359 this week!

**Turntables**

Pioneer PL45D: \$119  
Dual Mod I: \$108  
Dual Mod II: \$118

Dual Mod III: \$139  
BSR 20BPX: \$79  
Garrard 770M: \$79  
Garrard 990: \$125  
Miracord 825C: \$119  
Garrard 125SB: \$69  
BSR 810: \$99

**Receivers**

Rotel 102: \$119  
Pioneer 434: \$129  
Concord CR110: \$99  
Marantz 2230: \$249  
Pioneer SX650: \$239  
All Sherwood and

Sylvania: @Dealer Cost!!!!!!!!!!!!!!!!!!!!

**Tape Recorders**

Teac 400: \$249!!!!

**Loudspeakers**

EPI 180: \$150 each. Many other speakers in individual stores; quantities limited.

PLUS MANY MANY UNADVERTISED SPECIALS!!!!!!!!!!!!

182 Massachusetts Ave, Cambridge 864-HIFI

In Massachusetts: Harvard Sq., Comm. Ave., Newbury St., Waltham, Stoneham, Framingham, Dedham, Quincy, Hanover, Brockton, Worcester, Amherst and Northampton.

Stores also in New Hampshire, Vermont, Rhode Island, Connecticut, New York, New Jersey, Pennsylvania, Ohio and Michigan.

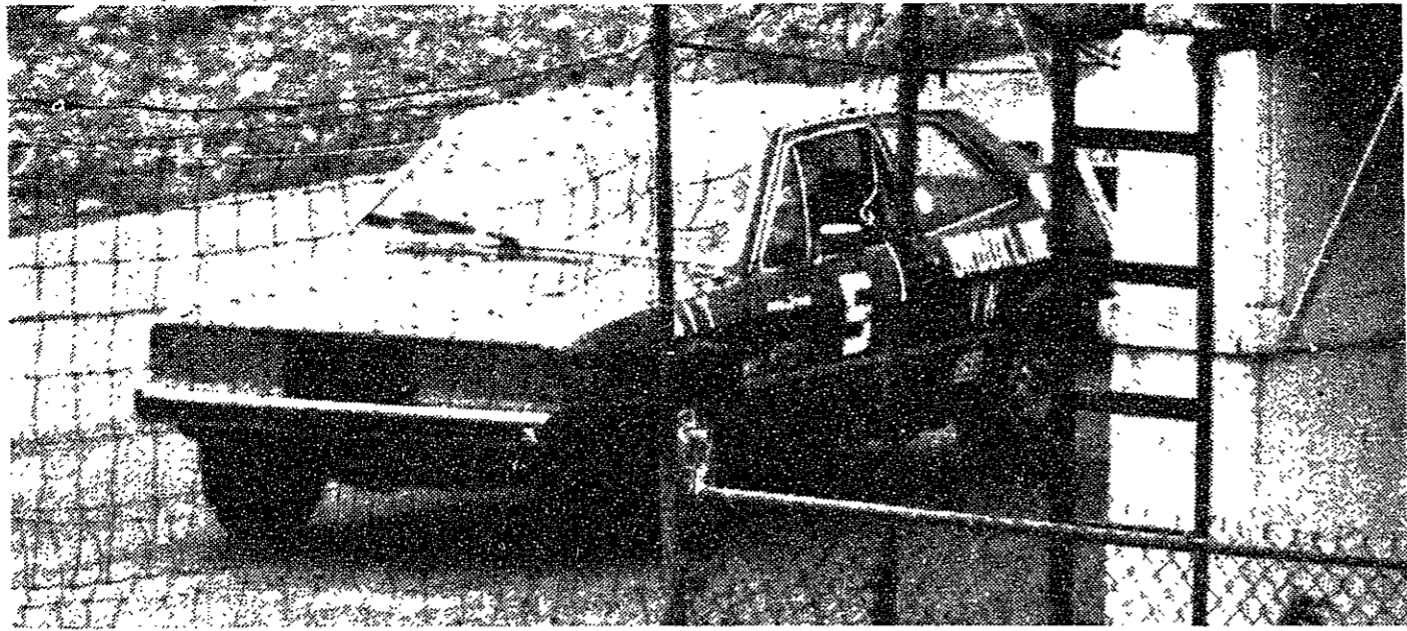

David Schaller

## Bradley takes first in auto race

By David Schaller

Last Sunday at Bryar, New Hampshire, the MIT Auto Club scored an impressive win as driver Joel Bradley ran away from the rest of the ten car showroom stock field.

Although the weekend was intended to be a shakedown race in preparation for the Car and Driver Challenge on October 16th, the team found that the Brookline VW Scirocco was in perfect shape. Bradley showed that the car would be at the front during practice on Saturday, when he unofficially broke the track record by over a second.

During the qualification session

Sunday morning the combination of cool air, a warm track, and the practice session from the day before gave Bradley another second's worth of speed, which made his fastest official time two seconds under the old track record, and earned him the pole position.

Since the second fastest car was exactly two seconds per lap slower than the MIT/Brookline VW Scirocco, it appeared that Bradley would have no real threat during the race unless he suffered a mechanical problem. The next three cars were within a second of each other and it looked like they would provide the excitement for

the race.

At the start Bradley quickly started moving away from the rest of the field, and by the third lap had opened up a lead of over ten seconds. For the rest of the race the distance remained about the same as Bradley slowed down to conserve the car. At the finish Bradley had slowed to a four second margin, with a Volkswagen Rabbit finishing second behind him.

The team will be going down to Lime Rock, Conn., next weekend for another race and extra practice in preparation for the Car and Driver race which will also be held at Lime Rock.

## Baseball tipped by Lowell; fall record now at 1-2

By Tom Curtis

The inexperience of MIT's varsity baseball team was clearly evident in Friday's game against Lowell on Briggs Field. Three errors in the first two innings set the tone for the game in which Lowell's 13-hit attack, aided by five MIT errors, led to a 14-5 defeat of the Beavers by the Indians. The loss lowered MIT's fall record to 1-2 after a 10-0 opening loss to Massachusetts Bay Community College and a 7-1 victory over Babson.

After the first three errors gave the Indians two unearned runs, Lowell hitting went to work, pounding out three runs in the third and two more in the fourth for a comfortable 7-0 lead. Kenny Smith '77 managed to hold the Indians in check in the fifth, setting the Lowell batters down in order. Lowell soon put the game well out of reach, embarrassing MIT with a six run sixth inning. Again, Beaver errors were responsible, five of the runs being unearned. Overall, half of Lowell's runs were unearned.

Fortunately, Beaver hitting was better than its fielding, producing its first runs in the fourth. After keeping the Beavers hitless for

three innings, the Lowell pitcher weakened, walking Bob Maresca '78 and Joe Krakunas '79. Phil Bugnacki '78 then popped a single to right, breaking up the no-hitter. Following a fielder's choice which forced out Maresca at the plate, John Hayashi '79 sent a single to center scoring Krakunas and Bugnacki.

In the bottom of the sixth, the Engineers scored three more runs. With two outs, co-captain Dan Sundberg '77 singled to center. After Tim Gaverick '80 drew a walk, MIT's other co-captain Steve Maconi '77 doubled, scoring Sundberg. Pete Steinhagen '79 walked, loading the bases. Jay Coopridger '79 then singled, scoring Gaverick and Maconi.

The effort was too late, however, as Lowell's lead was already a commanding 13-5. An Indian solo home run in the seventh completed the scoring.

Coach Francis O'Brien stated that the team is in a state of rebuilding after losing eight seniors from last year's 14-11 squad. Furthermore, he stressed that one of the purposes of the fall season is to try new players and give them game experience. He started no seniors and substituted freely, using nineteen players.

## DO QUESTIONS INTEREST YOU?

If you accept the idea that human genetic experimentation will be regulated, what would be that agency's structure? Powers? What will be the effect on scientific inquiry in general? What legal system is appropriate for a large space station, such as the one engineered by 16.86? What are the civil rights implications of a National Police Force to protect the plutonium cycle? Can a Chi-squared test be comprehended by a typical American jury? Should an individual have a legal right to die by refusing heroic medical measures? How should the invasion of privacy and abuse of consumers possible with EFTS be avoided? Do you feel that there is an ever-increasing need for people able to function on the law-science interface? If so, we (students and faculty) want to talk to you about our law science school (Franklin Pierce Law Center, Concord, N.H.) and its law-science program tomorrow at 4:00 P.M. in room 10-179. Students interested in 'normal' lawyering are also welcome.

↔

### TRANSLATORS

NATIVE SPEAKERS of Arabic, Bulgarian, Chinese, Dutch, Farsi, French, German, Greek, Italian, Japanese, Polish, Portuguese, Russian, Spanish, Swedish, and other languages needed for translations into foreign languages in various fields of engineering and science. Well-paid with convenient arrangements to suit your time schedule.

Experienced into-English translators and foreign language typists also needed for free-lance assignments in all languages.

Call Dr. Jauregui on 864-3900.

116 Bishop Allen Dr.  
(Formerly Austin St.)  
Cambridge, MA 02139

## Boston Symphony Open Rehearsal



Wednesday  
October 6 at 7:30 pm  
Seiji Ozawa  
Conductor

Andre-Michel Schub  
pianist

works to be rehearsed  
ALL BEETHOVEN  
'Prometheus' Overture  
Piano Concerto No. 5  
'Emperor'  
Symphony No. 7

Michael Steinberg,

Director of Publications of the Boston Symphony Orchestra, will host an informal discussion period beginning at about 6:50 pm in the Cabot-Cahners Room at Symphony Hall. So come early.

All seats unreserved at \$3.00

All proceeds benefit the Orchestra's Pension Fund

## GET A KICK OUT OF...



Kickers, 301 Brookline, 1976, Kickers Ltd., Hartford, Conn.

## DEMONSTRATION OF



## CALCULATORS & ACCESSORIES

Demonstration of all models featuring the New HP-67 and HP-97  
Wed. Sept. 29 from 11am to 3pm



M.I.T. STUDENT CENTER

## MIT Seniors in Mechanical Engineering

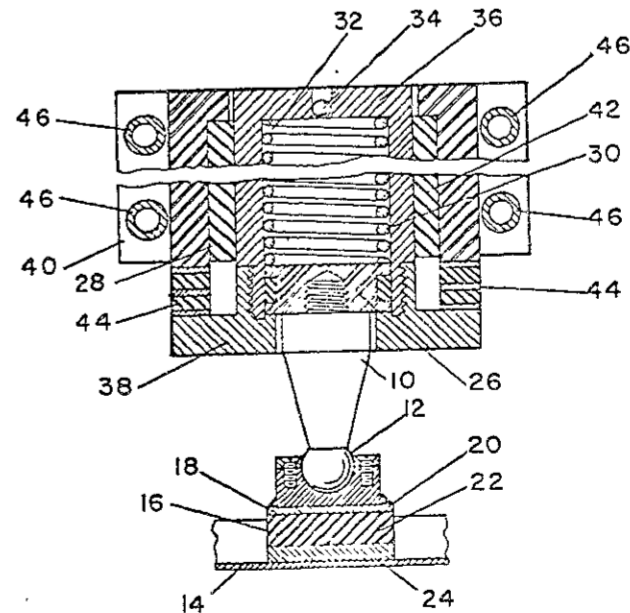

to help build new 60mph impact bumper for automobiles to be tested in June of 1977.

Contact John Wenckus  
899-3464 nites, or  
MIT dl9166 days.

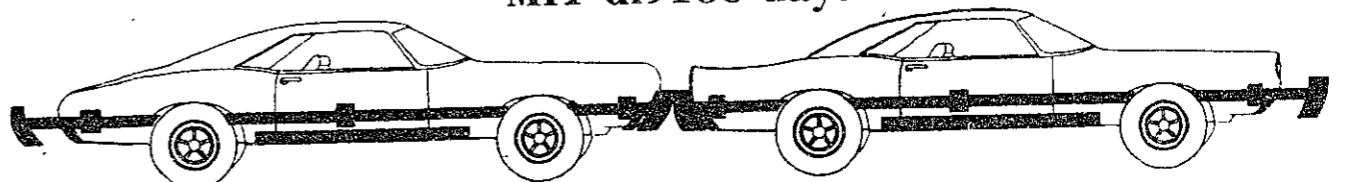

## Babson squeaks by MIT

By Glenn Brownstein

It will go into the record book simply as a 2-0 loss to Babson, but, in one of MIT's finest games in many years, the Engineer soccer team played the defending NCAA Division III champions to a standstill for over 60 minutes before going down to a hard-fought defeat.

The MIT booters, injury-prone the last two years and much-maligned for many more (the Engineers have not had a winning season in a dozen years), performed exceptionally well in a critical "benchmark" game against one of the East's stronger teams, and gained some measure of respect for a squad that gets little, if any, public notice.

Engineer goalie Tom Smith '78 was superb, upstaging Babson's All-New England goalie Shane Kennedy, who registered his 37th career shutout, an area record. Smith made a half-dozen point-blank saves and a few others from seemingly impossible angles to keep MIT in the game.

Only Babson's All-New England halfback Franz Grueter could penetrate Smith's defense, pumping in one shot from a pack in front of the net at 60:14, and adding a penalty shot at 86:05 to seal the win.

Although MIT's offense managed only eight shots on Kennedy, Engineer strikers Alex Ilroi '79 and Robert Currier '79, and

halfback Laird Cagan '80 put pressure on the Babson defense for much of the contest.

The game was evenly played for about 20 minutes before Babson's superior skills gained them the edge for the remainder of the first half. Though play was consistently in the MIT end of the field, Babson could not put the ball in the net, hitting the crossbar and post a couple of times each.

In the second half, Babson again controlled play, but after Grueter's goal, MIT appeared to improve rather than fold, and had the advantage for about a ten-minute span.

Captain Frieder Krups '77 anchored the MIT defense, seemingly covering the entire field, and making the big stop almost every time Babson came downfield. Sophomore Paul Thompson also excelled on the Engineer fullback line.

Coach Walter Alessi remarked, "if we play like this all season, the wins are going to come." He cited the play of Thompson and Smith, and added that "we have nothing to be ashamed of — it was a great game."

MIT will travel today to Worcester Poly, which received votes in the pre-season New England small-college soccer poll, and lost to Babson 4-0 earlier this season. The Engineers then take on Trinity in Hartford on Saturday morning.



Lampros Fatsis '77 (above) rushes in as Babson's Shane Kennedy makes the save. The MIT offense was unable to score on the All-New England goalie, but the Engineers played one of their best games in years, holding NCAA champion Babson to a 2-0 score. Alex Ilroi '79 (right) was a mainstay of the Engineers' defense in Saturday's game.

Mark James

## X-country takes Engineers' Cup

By Dave Dobos

Paced by senior All-American Frank Richardson's record-setting run, the MIT cross country team trounced both Rensselaer Poly and Worcester Poly in Troy, New York last Saturday to bring the Engineers' Cup back to Cambridge.

MIT's low score of 24 far outdistanced runnerup WPI's 39. RPI trailed with 60. MIT had not captured the cup since taking it at RPI three years ago.

Richardson, who won the 5.0-mile race by over 400 yards, shattered the course record of 26:08 with a winning time of 25:04. In second place was MIT's Chris Svendsgaard '78. His 26:11 performance was only three seconds off the former course mark. John Krolewski '77 and Barry Bayus '79 ran solid races for fifth (26:48) and sixth (26:49) places, respectively. Freshman Dave Westenberg rounded out the MIT scoring team, finishing tenth overall in 27:05.

Fourth year coach Pete Close termed it "a heckuva win." MIT

had dropped Engineers' Cup races to WPI the previous two season openers, starting otherwise successful years on a bad note.

Close was especially pleased with the double victory because he believes that this year's team lacks varsity running experience. Although six lettermen (Steve Keith '77 and Tom Clark '79 in addition to the four upperclassmen mentioned above) are returning, only three consistent scorers from the 1975 squad are back. He feels that the Engineers face a rebuilding situation, one of developing the new talent to challenge and therefore improve the existing varsity runners.

Close's team goals for the year point to both a successful dual meet season and a berth to the NCAA Division III (small college) National Championships in the New England area qualifier on October 23. MIT must place in the top six in the qualifying meet to make it to the Nationals hosted by Case-Western Reserve in Cleveland on November 13.

Richardson, who is also the

team captain, is more verbal about the Division III qualifier and feels that this meet should be a primary focus of the squad's efforts. He thinks that the victory over RPI and WPI will be very important to the outcome of the season for the Engineers.

Enjoying an undefeated dual meet season and finishing fifth in the Nationals last fall, Richardson's personal goals are to improve his performances over those of 1975. Close feels that Richardson is in the best shape of his life and could easily reach the heights that have been hoped for him. Coach and athlete alike were pleasantly surprised with Richardson's pre-season victory in the Northeastern Invitational on September 18 at Franklin Park. His time of 24:43 was only 13 seconds off his personal best there.

Both varsity and JV now stand at 2-0 due to the junior varsity's preliminary double thrashing of RPI and WPI. Tim McMahanus '80 covered the 3.9-mile course in 21:41 to take individual honors.

## Ruggers edge Coast Guard

By Charles Cox

The MIT Rugby Football Club played three games this weekend, scoring a victory over Coast Guard on Saturday but losing twice to Tufts on Sunday.

In Saturday's game the MIT B side defeated Coast Guard's A-team, 17-16. Coast Guard dominated the first half of play, chalking up a try from a scrum three yards out from the goal line, and penalty goals from 30 and 20 yards. In the second half, Dave Cope '79 blocked a 25-yard drop-out that set up a try-scoring run by Jim Peet to put MIT on the board. John Kavazanjian converted.

The Engineers then pressured Coast Guard, causing them to make mistakes and lose ground. Gilles Laurent G went over for a try, then John Kenny '79 scored after recovering a kick by Michel Faral. Kavazanjian put MIT into the lead to stay with a three-point penalty goal.

Coast Guard almost pulled the game out of the fire by running a penalty kick from five yards out for a try and conversion, but a final tackle-breaking run that appeared to be a score was judged out of bounds.

The Engineers traveled to Tufts on Sunday for two games matching the MIT and Tufts A teams, and the MIT C side versus Tufts' B squad. In the first game, the narrow field hampered passing movements in the Engineer backfield. Play flowed up and down the field without advantage to either team until the Jumbos dropped a goal late in the first half to grab a 3-0 halftime lead. MIT threatened several times in the second half, but to no avail as the Jumbos triumphed, 9-0.

The MIT C-team fared little better against the Tufts B side. Early in the game the Jumbos booted a penalty goal, then blocked an MIT kick to tally a try before Tom Bryant G could answer with a penalty goal to close the half.

The Jumbos started second-half scoring with a try following a line-out. MIT fought back, taking the lead with a penalty goal by Bryant and a try by Walter Laird '79. Bryant converted the try.

MIT's lead evaporated on the next series of plays, however, as the Jumbos forced the ball over from a scrum three yards out. The try was converted, and Tufts was victorious in the 17-12 contest.



Mark James

### IM soccer results:

A-League Independent	
ASA	2
Chinos	2
Aero/Astro	6
Club Latino	1
Metallurgy	0
Economics	0
A-League Living Group	
Sigma Chi	3
LCA	5
FIJI	2
East Campus	1
Baker House	1
DTD	1
B-League	
SPE	1
PLP	1
Chem E	0
MacGregor F & G	2
TDC	1
SAE	2
AEPi	1
Kappa Sigma	1
Mech/Nuc E	1
Number Six Club	*0
Nuke E	0
MacGregor E	*0
PDT	0
Chi Phi	0
Ashdown	0
Beta Theta Pi	1
C-League	
ATO	2
PiKA	0
Bexley	1
Theta Xi	2
PBE	2
Burton One	1
Conner Three	0
MacGregor B	2
Virjins	2
Burton Third Bombers	4
Senior House	2
PKE	3
ADP	1
PKT	1
ZBT	0
SPE 'C'	0
Theta Chi	0
Baker Beggars	0
MacGregor A	0
Burton Five	0
New III Stooges	1
Conner Five	0
Joe's Bar & Grill	0
Student House	1
DKE	1
PSK	*0

\* denotes forfeit.