

Students address Visiting Committee

By Stuart Gitlow

Last Friday night, the MIT Corporation Visiting Committee on Student Affairs held an open forum at which approximately 60 students explained their opinion of specific aspects of life at MIT.

Although no responses were given by the committee, D. Reid Weedon, Jr. '41, Chairman of the Committee, commented that the panel discussion was of great assistance to the Committee. He added, however, that "I can't promise which [opinions] we'll discuss in more detail."

John DeRubeis '83, Undergraduate Association President (UAP), gave the results of a Lobby 7 pillar poster which had asked students what they would like to tell the Visiting Committee. According to the poster, students were disturbed by the commons situation and requested unlimited seconds and replacement of the current Dining Service. Students also requested a response to rumors of permanently crowded rooms in East Campus. DeRubeis read one specific comment to the panel which stated that a twenty percent rise in tuition should be replaced by a three percent rise in research fees.

Students responding to the poster commended the Campus Police, the Medical Department,

and the Undergraduate Academic Support Office (UASO).

Many students speaking at the meeting expressed concern over prejudice toward cultural groups on campus. Arturo Chavez '83, a member of Spanish House, told the panel that the two-year old living group has tried to expand but that "we don't think the Dean's Office is supportive of our living group." Next year, Chavez said, Spanish House will be allocated no more rooms than it currently has.

Eduardo Grado '82, president of the Mexican-American Student Association, said that there is poor cultural and social awareness at MIT. He asked that there be more support of the Human Relations Committee. "I don't think one night every two years will do it," Grado told the committee.

Tony King G, president of the Chinese Students Club, said that the CSC has been treated as a foreign students club by the Dean's Office. The budget of the club and its allowed use of MIT facilities has "fallen behind that of other student clubs," King said.

Jason Weller '82, Vice-Chairman of the Finance Board (FinBoard), voiced the opinion of many students when he said, "I (please turn to page 9)



Student leaders dine with faculty and members of the Visiting Committee on Student Affairs last Friday afternoon. (Photo by Jonathan Cohen)

Bio company agrees to joint venture in cell production

By Kenneth Snow

Flow General, Inc., of McLean, Virginia, has entered into an exclusive agreement with MIT to continue work on a patented method for mass production of mammalian cells. The commercial process was developed at MIT by researchers in the Department of Nutrition and Food Sciences.

Under the terms of the agreement, Flow will pay a minimum royalty of \$400,000 each year to MIT. Mr. J.E. Hall, president of Flow General, came to MIT on Friday, May 1, to deliver the first installment in the agreement, a check for \$100,000, to President Paul E. Gray '54.

As part of the negotiation, MIT has agreed that after the inventor's royalties are deducted, 50 percent of the money from Flow General will be given to the Department of Nutrition and Food Sciences to establish a fund to support projects in the field of cell biology and biotechnology, according to an MIT spokesman.

The cell culture method was invented by Dr. William G. Thilly

'67, associate professor of genetic toxicology, and Dr. Daniel I.C. Wang '59, professor of biochemical engineering.

Two students, Dr. David W. Levine '69, then a graduate student, and Jason S. Wong '75, a technical assistant in the Department of Nutrition and Food Sciences, also worked very heavily on this project. Thilly stressed that the work done by Levine and Wong was indispensable.

According to Thilly, Flow General stock was selling for \$4.50 a share in 1976. Last week, after the announcement, the stock split after surpassing \$100 a share.

Thilly explained that the idea for the project came from a Dutch (please turn to page 3)

Gray offers open office hours, reflects on year as president

By Stephanie Pollack

To "try to be accessible to students who want to seek me out," President Paul E. Gray '54 will schedule open office hours beginning next fall.

The open hours will initially be for students only, although the practice may be expanded to include other members of the MIT community later, according to Gray.

Evaluating his first year as president, Gray expressed concern that "I have spent far too much of my time on routine tasks and far too little time on long-term, strategic planning." Gray said, "One thing I would put in the category of accomplishment" is the effectiveness of "the in-

dividuals and team in the Office of the Provost." He called the appointment of three academic deans in the past year a substantial accomplishment, noting that the appointments had taken a large amount of time during the year.

Gray also evaluated his progress on some of the issues raised in his Inaugural address. He said there was a need for MIT to "revitalize our own internal processes" for increasing diversity in admissions and employment. Gray said that MIT is "falling short of our goals" in the employment of women and minorities. Gray was wary of using the phrase affirmative action, calling it "a contributor to non-

communication — it's one of those code words that means different things to each side."

Gray remarked that he was disappointed that there had been "less movement on the issue of pace than either they [the Committee of Educational Policy] or I would like to have seen." While applauding the discussion on pace generated by his Inaugural address, Gray said that he had discovered that pace is "an issue that relates to a way that a culture behaves, and changing a culture is very difficult."

The curriculum review currently being undertaken by the Committee on Educational Policy is considering two separate issues, according to Gray. One type of change being examined involves the rules regulating the curriculum, which may relate to the problem of pace, Gray noted. He cited the procedures for counting units as an example of the procedural issue. Gray said that the current system "gives the impression of two significant figure accuracy" in determining how much work goes into a course. He suggested that courses be counted as half-courses, and that four or five courses per term be established as a normal load.

The second type of issue being examined in the curriculum review is substantive, such as the role of science distribution requirements, according to Gray. He said that science distributions were created to "diversify the student's encounter with science and technology," but that the classes no longer "serve a broadening purpose."



Paul Gray reviews his first year as President of MIT during an interview with *The Tech* last week. (Photo by Jonathan Cohen)



George Huffman G was one of five MIT students awarded Karl Taylor Compton Prizes in ceremonies held yesterday morning. The other winners were Sarah Axel '81, Anita Bliss '81, Judith Frankel '81, and Steven Solnick '81. (Photo by Steve Cohen)

Press cited for science policy contributions

By Sarah Bingman

"We are sorry he's leaving; we wish him well and the best of luck to him and the [National Academy of Sciences] for the next six years," offered Francis E. Low, Provost and moderator of a symposium in honor of Frank Press last Friday in Kresge Auditorium.

Press, Institute Professor, former Head of the Department of Earth and Planetary Sciences, and former Director of the Office of Science and Technology Policy and science advisor to former President Carter, will assume the presidency of the National Academy of Sciences (NAS) this July.

John G. Sclater, Professor of Marine Geophysics, and Irwin I. Shapiro, Professor of Geophysics and Physics, spoke at the symposium of their association with Press as well as their respective fields of research. Jerome B. Wiesner, President Emeritus and Institute Professor continued by addressing problems facing Press and the NAS.

"He has done a wonderful job setting up joint programs at Wood Hole [Oceanographic Institute]," said Sclater. He also praised the high standards that Press achieved in the department and the Woods Hole program.

Sclater's technical talk on plate tectonics was entitled "Oceans and Continents: Similarities and Differences in the Mechanisms of Heat Loss," in which he discussed thermal boundary layers and heat convection.

Shapiro thanked Press for his support in research projects, and credited Press with the encouragement and support necessary to begin and continue his optics experiments for the past 14 years.

"Through a Lens Brightly: Gravitational Images in Space," the subject of Shapiro's talk, concerned images in space caused by massive bodies. Shapiro's speech included the history of the theory and its founders' trials and triumphs.

Wiesner praised Press for his many interests outside of science, his "amazing intellect," and his "many contributions," especially the joint Woods Hole degree program. He recalled that Press decided to accept a professorship at MIT only after "he fell in love with the students" during a visit.

Wiesner listed many of Press's accomplishments with both foreign and domestic governments. Wiesner thanked him for initiating technological exchanges, especially with China, and for increased scientific and technical understanding with Russia. As to Press's contributions to improving respect for science in America, Wiesner commented, "He has played an important role in bringing the [role of] science advisor back into important issues."

However, "The government doesn't want advice," Wiesner warned, reflecting on budget cuts in the National Science Founda-

(please turn to page 8)

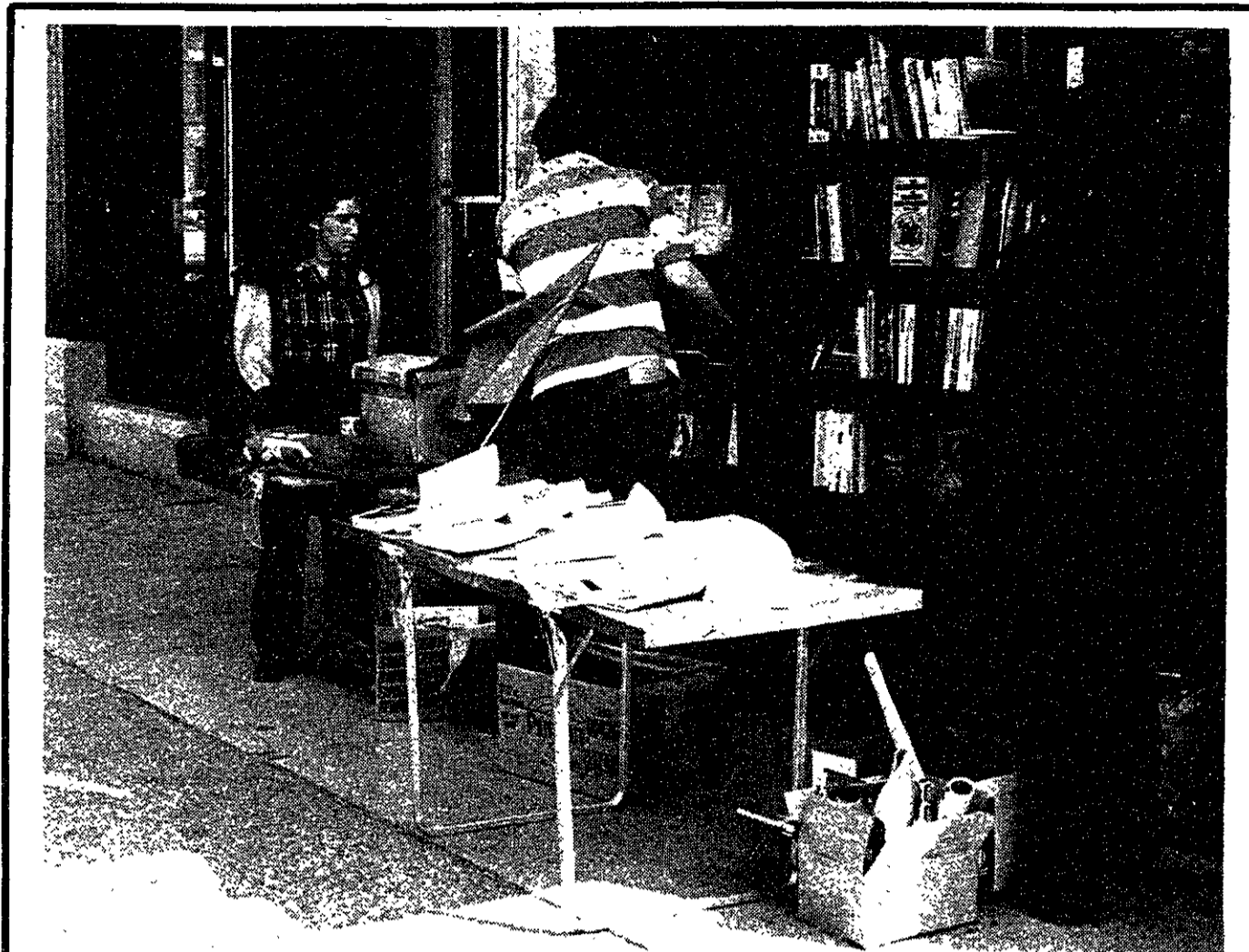

Revolution Books was evicted yesterday morning from its store at 233 Massachusetts Avenue. The location will be used by MIT for the Zeta Psi fraternity.

According to Bruce Pritchard, spokesman for Revolution Books, "For them, it's a small victory, substantial but not significant." Presently, the store has no definite place at which to relocate.

Pritchard noted that when the movers came Monday morning, they removed the red flag from the store. When they asked where they should bring it, they were told to "bring it to Central Square." It was delivered in the square next to supporters of the store. Pritchard noted that the flag is like the issue at hand. "It may temporarily be seized, but the red flag will reappear in the hands of the people."

- Kenneth Snow

(Photo by Steve Cohen)

NEAT OPPORTUNITY

Apartment Exchange between San Diego/Boston.

Dates June 8-15. Two Room elegant apartment on Mission Bay with swimming pool, extras and car in exchange for same in Boston Area.

Responsible persons only.

Pheobe Simmons, Asst. Manager, Radio Station. W:(714) 265-6431; H:(714) 270-3390.

Business? Pleasure? Check out American Airlines \$300 fare.

EASTERN AIRLINES is seeking students (Business/Social Science Majors) who will be sophomores and juniors in the 1981-1982 academic year.

Students should be in good academic standing and would be required to work 20-30 hours a month. Monthly salary plus travel benefits.

Interested applicants please send resumes to:

CAMPUS REP PROGRAM
%EASTERN AIRLINES
Personnel Office
Logan International Airport
East Boston, MA 02128

Central War Surplus

433 MASS. AVE.

Central Square

Cambridge

GOING CAMPING?

SAVE ON:

- Sleeping Bags
- Tents & Air Mattresses
- Backpacks & Knapsacks
- Ponchos
- Coleman & Gas Stoves

EVEN IN SPACE
THE ULTIMATE ENEMY IS STILL MAN.

OUTLAND

SEAN CONNERY in
"OUTLAND"
PETER BOYLE

FRANCES STERNHAGEN JAMES B. SIKKING KIKI MARKHAM
Produced by RICHARD A. ROTH Executive Producer STANLEY O'TOOLE
Music by JERRY GOLDSMITH Written and Directed by PETER HYAMS

R RESTRICTED
UNDER 17 REQUIRES ACCOMPANYING
PARENT OR ADULT GUARDIAN

PANAVISION
TECHNICOLOR

70MM DOLBY STEREO
IN SELECTED THEATRES

A LADD COMPANY RELEASE

THROUGH WARNER BROS.
A WARNER COMMUNICATIONS COMPANY

Copyright © 1981 The Ladd Company All Rights Reserved

READ THE WARNER BOOK

SPECIAL ENGAGEMENTS BEGIN MAY AND JUNE

news roundup

World

Socialist wins Presidential election in France — Francois Mitterand was elected President of France yesterday. Mitterand's election for a seven year term was seen as the biggest political shift in France in a generation. Socialist candidate Mitterand defeated the incumbent, Valery Giscard d'Estaing.

Reagan's envoy to the Middle East meets with Syrians — Philip C. Habib met yesterday with Syrian President Hafez al-Assad to discuss the dispute between Israel and Syria over the placement of Syrian anti-aircraft batteries in southern Lebanon. Habib delivered a letter from President Reagan to the Syrians, but declined to comment about either the letter or his meetings.

Ex-Beatles' Lennon tribute to be released — Paul McCartney, George Harrison, and Ringo Starr have collaborated on the recording of *All Those Years Ago*, written by Harrison as a tribute to late Beatle John Lennon. Scheduled to be released this month as a single, the recording features Starr on drums with McCartney and his wife Linda harmonizing. The recording is to become a cut on an upcoming Harrison LP.

Nation

Reagan aides propose guest worker plan with Mexico — The Reagan Administration is considering a guest worker plan under which hundreds of Mexicans would be allowed to enter the country and work on a temporary basis. This proposal is seen as an effort to improve US-Mexican relations, but it has met with harsh criticism from organized labor and many Mexican-Americans. The president has not yet reviewed or received advice on this program.

Format of LSAT's to change — Beginning in the summer of 1982, grammar, geometry, and quantitative math problems will be eliminated from the the Law School Admissions Test. While multiple-choice questions will remain as the bulk of the exam, at least one essay question will be added. Furthermore, the 200 to 800 point system will be replaced by a 10 to 50 point system.

New budget angers allies by cutting funds for joint science programs — Foreign governments, particularly of American allies such as France, West Germany, and Japan, have reacted strongly toward the budget revisions that President Reagan announced in February concerning curtailment of US involvement in various international scientific programs. These cuts include the international Solar Polar Mission which was to fly two spacecraft, one American and the other European, to opposite poles of the sun. The Reagan Administration has curtailed the US half of the project, while the Europeans have already spent \$100 million.

Frank Hrach and Stuart Gitlow

Weather

Cloudy and cool today with rain showers, stronger and more widespread this morning, diminishing somewhat this afternoon. Highs near 60 with southeasterly winds. Rain tapering to a few showers or drizzle tonight with winds shifting to the southwest. Lows near 50. For Wednesday, partly cloudy to mostly sunny with highs up to near 70. Chance of rain 80 percent today, 50 percent tonight, 20 percent tomorrow.

James Franklin

McCormick stop for weekend Wellesley bus to change

By Ivan Fong

The MIT stop of the Wellesley Senate bus will be changed from its current location in front of McCormick Hall to "probably somewhere down the road" beginning next fall, according to Harneen Chernow, Director of Transportation and Communication of the Wellesley student government.

The subject of changing the location of the bus stop was discussed at a meeting of the Wellesley Senate two weeks ago and the Senate voted to "look into viable alternatives," said Senate President Sally Ballentine.

Although there have been no official complaints, Wellesley junior Mary Grillo, former Special Assistant for Legislative

Affairs, remarked that she introduced the idea of changing the bus stop location because of complaints by McCormick residents, and because "we were never given official allowance to use [the lobby of] McCormick."

McCormick Hall President Sandy Waal '82 said that the subject was discussed at a house meeting several months ago, during which security problems in the early morning hours were mentioned. House residents decided then to suggest to the Wellesley Senate, who runs the weekend bus service, to consider changing the bus stop location for the late buses. Waal is also desk captain of McCormick Hall.

A problem with the current location, according to former McCormick President Anita Bliss '81, is that McCormick "has a guest-list policy, and although the lobby is a public area, when the night watchman leaves to make his rounds early in the morning, there is the prospect of students wandering around [the first floor]."

"This has never been a problem in the past," noted Bliss, "but lately it has been more and more acceptable for [Wellesley] women to sleep in [McCormick's] date rooms after missing the bus." She continued that although major incidents concerning Wellesley students at McCormick are rare, "There was one time when someone [from Wellesley] threw up in the lobby."

Although security seems to be the main problem, other McCormick residents say there are personal conflicts between MIT and Wellesley women when students who are drunk use McCormick's lobby. There are also complaints that "it is a hassle when people call us for the bus schedule and ask us for bus tickets."

Suggestions for a new location are still being considered, in-
(please turn to page 9)

MIT cell culture method has commercial prospects

(continued from page 1)

scientist Toome van Ezeal. Ezeal used the compound DEAE Sephadex as a base on which cells would grow. 100 thousand to 500 thousand cells per millimeter were able to grow on the beads, but when more beads were added, the cells died.

No major advancements were made in the next few years. In 1974, MIT planned to open its new Cell Culture Center. Thilly presented Ezeal's work as a prospective project, and the National Science Foundation funded \$8000 each year for his research. This was barely enough money to cover the expenses of research and did not cover the expenses of having a graduate student work on the project, noted Thilly. The project was catalyzed by Levine's research fellowship and Wong's search for a thesis topic.

The final process developed at MIT makes use of microcarriers. Microcarriers are little beads of Sephadex which, when given a positive charge, will support the growth of cells that require a solid surface on which to grow.

Conventional cell culture mediums utilize one-liter bottles that have a total inner surface area of 500 square centimeters. A one liter bottle will hold 40 million microcarriers, which increases the surface area to about 60,000 square centimeters. With

this surface area, cells can be grown to a concentration of approximately 10 million cells per millimeter.

Thilly noted that the patent is for the use of the microcarriers, marketed under the name "superbeads," as well as for the process of their production.

The growth of large numbers of cells is needed in the production of viruses, vaccines, hormones, interferon, and other by-products of cell growth.

Thilly used the Salk vaccine as an example of the prospects for microcarriers. Presently most of the world uses the Sabin vaccine, a cheap and easily produced vaccine, for the prevention of polio. However, the vaccine is not effective in many tropical areas which are presently plagued with a major polio problem. The Salk polio vaccine would alleviate this problem, even though it is presently expensive to produce. By utilizing microcarriers, the Salk vaccine will be made easily available to many parts of the world, according to Thilly.

Thilly said that this work is attracting scientists from all over the world to visit MIT. One such scientist, Jonas Salk, noted for the polio vaccine, will be speaking at MIT in October. "This is an invention whose users will have to work to get any use out of it. There's always a better mousetrap," Thilly noted.

the
Coop

MIT STUDENT CENTER

SUMMER
SPECIAL

Save Now On
**TYPEWRITER CLEANING
and
STORAGE**

Bring your typewriter into the Coop for complete servicing and we will then safely store it for the summer at no extra charge.

Select the type of service you need for your manual portable, electric portable (manual carriage return) or electric portable (automatic carriage return) typewriter.

**SPECIAL SUMMER PRICES
RANGE FROM \$31 to \$67**

Major repair and parts at additional cost. Office typewriters and Royal Electric Excluded.

TYPEWRITER REPAIRS: 492-1000, x339

Top Prices Paid!

For Used Paperbacks And Used Textbooks

Harvard Book Stores
1248 Mass. Ave., Cambridge (Harvard Square)
732 Comm. Ave., Boston (B.U.)

Stephanie Pollack

Caring about MIT

It is truly unfortunate that the end of the second term coincides with the beginning of spring. It always seems that the weather gets more and more pleasant as finals approach. Friday, for example, was far too beautiful a day to spend in a library or laboratory.

The weather was better suited to perching on a statue in Killian Court and watching the sailboats on the Charles River. Wading in the moat or sunbathing on Kresge Oval were also options for those brave enough to risk being attacked by runaway frisbees. The less athletically-inclined could sit on the steps of the Student Center or Lobby 7 and watch the world wander past.

Such lazy days are conducive to thinking, but not the type of brain-drain which improves one's grade point average. I thought about myself and MIT and how the two of us were getting along these days. An important change in our relationship occurred this term, although I can't figure out exactly when. Some time during the past few months I stopped being at MIT and became a part of MIT.

The distinction is an important one. Anyone who spends four years here and leaves with an undergraduate degree has been at MIT. Many students become alumni without ever feeling that they have been a part of MIT, however. The difference, I think, lies in caring.

Caring about MIT does not mean loving every person and place associated with the Institute. It is a much subtler feeling, a type of pride that comes from being a part of an important and interesting school. Even this pride should be muted, not the hubris of the ancient Greeks. It is possible, even easy, to brag about MIT without caring for the place; such praise can be merely a glorification of one's presence here.

I used to be proud to be at MIT because I was getting my education surrounded by Nobel prize winners and presidential science advisors and other important people. Now that I feel that I am a part of MIT, I think the real heroes are the students. Eminent professors are certainly important and worthy of praise. Prominent faculty members receive many forms of praise, however, while most students toil in relative anonymity.

Yesterday, some of these students were recognized for their achievements. Students who do not win Compton Awards, or even the 2.70 contest, can be just as important and caring as those who do, however. I have some special heroes: students who work on their humanities classes, tour guides who are honest but make pre-frosh want to come here, students who are active in activities or living groups but prefer accomplishments to recognition, researchers who are enthusiastic about their projects.

In very different ways, these students care about MIT. They may be just as burned out as their uncaring classmates at the end of the term, but they will not be miserable. Unfortunately, many students who care may be punished academically for devoting too much time to activities which are not reflected in grade reports. Others—those who care too much—may become discouraged trying to function surrounded by people who do not care.

For now, I will oppose the view of the majority and enjoy being at MIT. It will undoubtedly impair my ability to do academic work—some days will be spent solely on student activities, others simply wandering the halls and talking to MIT's special people to replenish my faith. Academics are not the sole measure of success at MIT, however. Many special people here taught me to care, and my goal is to show at least one other person why and how to care. Let my ability to impart this special pride to others be a measure of my success.

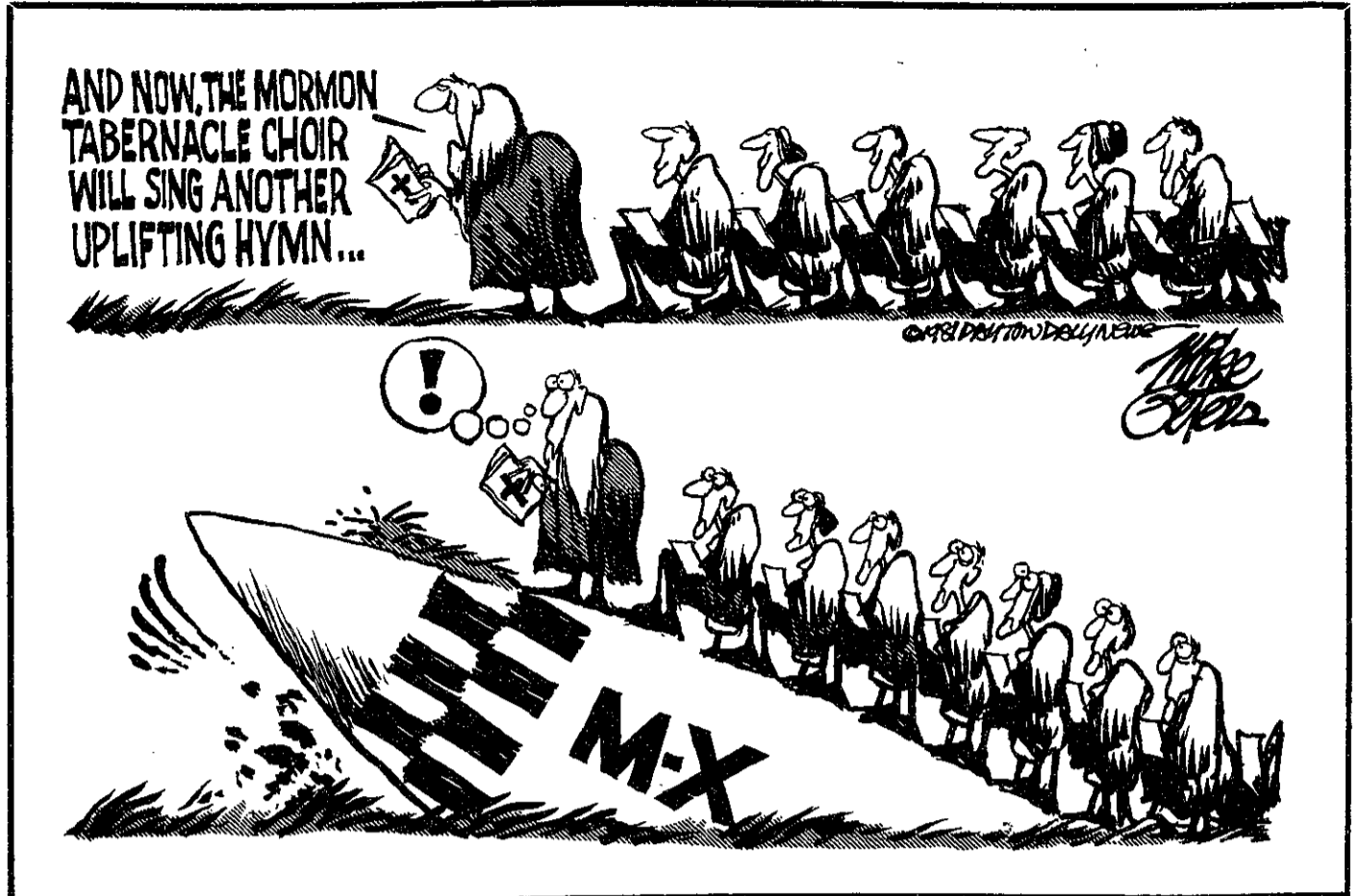

feedback

Serve a la carte in dorms

Editor's note: This is a copy of a letter sent to Director of Housing and Food Services Gene Brammer.

To the Editor:

The house dining rooms were established to provide a communal atmosphere for students to eat and interact in. Under the present commons system, students eating in the house dining rooms are required to pay for a full meal, regardless of what they actually purchase. Students wishing to buy a la carte must walk to either Lobdell or Walker, which is inconvenient at best in cold or inclement weather. Buying a la carte at Lobdell, although cheaper, deprives the student of the social benefits of eating in a house dining room.

Many students who do purchase meals within the house feel compelled to eat as much food as possible in order to get their money's worth, often eating one large meal a day while skipping the other two. After eating such a meal the student feels bloated for several hours, while the next day brings hunger pangs in the last hours before the next meal.

If given the option of either buying a la carte or using points, more students would eat regularly in the dining room, purchasing only that amount of food which they intended to eat. This would improve the social aspects of commons, as well as allowing the

students to tailor their meal consumption more to their own needs.

Certain changes would have to be made in the dining rooms to accommodate a la carte users. Beverages and bread, currently outside the serving area, would have to be placed before the checker. The salad bar could remain where it is, the bowls for it being placed before the checker, so that only students who purchase bowls would be able to use it. These changes would be accomplished by moving the checkers out a few feet further, since serving lines at their current lengths can't handle drinks and bread.

Every time a student brought food out from the serving area,

the validine card would be presented. A la carte purchases would be rung up with no problems. If a student had already purchased a commons meal, the terminal would show this, so that additional drinks and rolls could be eaten. Students attempting to bring out food this way who had not paid meal points would be charged for a meal, thus discouraging fraud on the system.

We believe that having a la carte meals as an option in Baker, MacGregor, McCormick, and the new facility at 500 Memorial Drive is feasible, and urge that this proposal be adopted by the Dining Advisory Board.

DormCon Commons Committee

Best way to maintain peace is to deter war

To the Editor:

Picture the headline "US Military Begins to Disarm." How many of you peace lovers have waited to see this day? A day when the threat of nuclear holocaust would no longer be with us and people could live without fear. Death and destruction would no longer overshadow us, but rather advances in medicine and scientific fields would surround us. The money that would be saved could be put

into programs to benefit the country and its people.

This is a great anthropological ideal, but we must ask ourselves one major question. Would this utopian ideal work? If we turn to history to give us a clue, we are confronted with countless examples that say it will not work. Nations as well as people will always try to influence and impose their beliefs on weaker parties. We would soon be overwhelmed with

(please turn to page 6)

The Tech

Brian J. Glass '82 — **Chairman**
 Stephanie L. Pollack '82 — **Editor-in-Chief**
 Jon von Zelowitz '82 — **Managing Editor**
 Richard W. Epstein '83 — **Business Manager**
 Volume 101, Number 25
 Tuesday, May 12, 1981

PRODUCTION STAFF FOR THIS ISSUE

Night Editor: Bill Giuffre '84; **Staff:** Robert W. Leishman '82, Kevin Osborn '82, Jon von Zelowitz '82, Jack Link '83, Bill Spitzak '83, Charlie Brown '84, Stuart Gitlow '84.

NEWS DEPARTMENT

News Editors: Ivan K. Fong '83, Jerri-Lynn Scofield '83; **Associate News Editors:** Stuart Gitlow '84, Frank Hrach '84, Thomas Loreda '84, Tony Zamparutti '84; **Staff:** Lawrence Choi '81, Michael J. Potter '82, Michael Shimazu '82, Kenneth Snow '82, Sarah Bingman '83, David Lingelbach '83, Timothy M. Kneale '84, Selina Lin '84, Barry S. Surman '84, Alain d'Heurle G.; **Cartoonists:** Glen Apseloff '81, V. Michael Bove '83, Bill Spitzak '83; **Meteorologist:** James Franklin G.

SPORTS DEPARTMENT

Sports Editor: Eric R. Fleming '83; **Staff:** Steve Kim '83, Eric Brandt '84, Nick Rowe '84.

ARTS DEPARTMENT

Arts Editor: Lisa Buchholz '81; **Associate Arts Editor:** Mark DeCew '84; **Staff:** Eric W. Brown '81, Kevin Cunningham '82, Joseph Kristl '82, Heidi Picher '82, Eric Sohn '82, Calvin Gabrel G., Jonathan Richmond G.

BUSINESS DEPARTMENT

Advertising Manager: Allen Frechter '83; **Distribution:** Bill Ogilvie '81; **Circulation Manager:** Cullen Johnson '81.

The Tech (ISSN 0148-9607) is published twice a week during the academic year (except during MIT vacations), weekly during January, and once during the last week in July for \$7.00 per year Third Class by The Tech, 84 Massachusetts Ave Room W20-483, Cambridge, MA 02139. Third Class postage paid at Boston, MA. Non-Profit Org. Permit No. 59720. **POSTMASTER:** Please send all address changes to our mailing address: The Tech, PO Box 29, MIT Branch, Cambridge, MA 02139. Telephone: (617) 253-1541. Advertising, subscription, and typesetting rates available. © 1981 The Tech. Printed by Charles River Publishing, Inc.

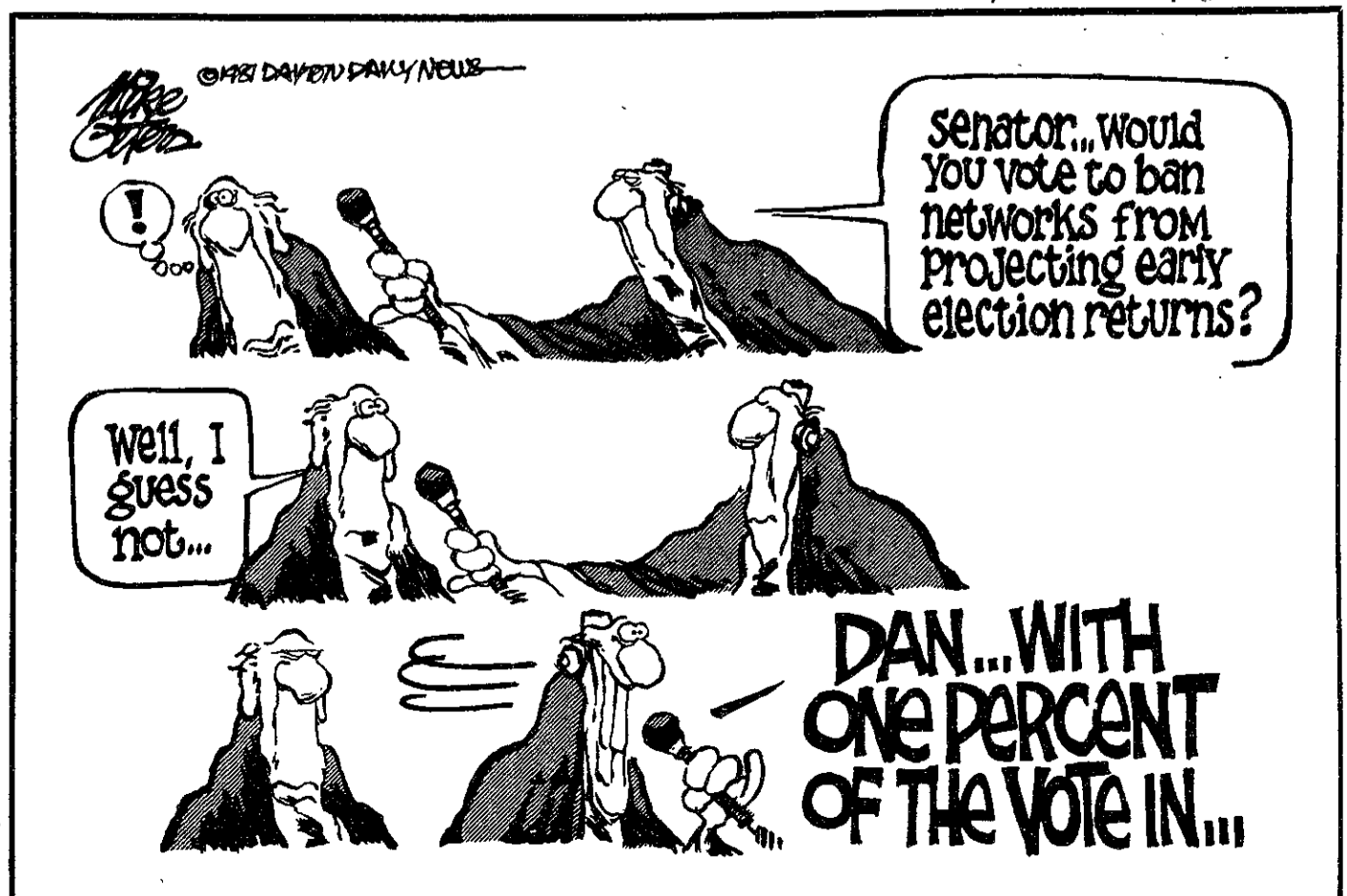

Gays reply: homosexuality not a habit

Coming to grips with homosexuality

To the Editor:

How is it that the disparity between intellect and social awareness is as large as it is here at MIT? Why must the community continually suffer from vandalism and verbal abuse based on racial, religious, and sexual prejudice? How is it that MIT students such as Daniel Milliron so grossly misunderstand the human condition that they can hold the tenets he expressed in his letter of May 8, 1981?

Mr. Milliron, I am a male undergraduate quite familiar with the choice that gay people have before them. Very recently, I began to come to grips with the fact that I am attracted to members of my own sex. I have begun to fight the societal conditioning that we are all subject to that has made me believe that homosexuality is sinful, repulsive, and disgusting. For at least five years, since the first time I can remember having any gay feelings, I have been ignoring them, denying my instincts, and forcing myself to date women, so as to appear "normal" to both society and to myself.

Well, I'm tired of the charade, tired of the frustration of trying to be someone that I'm not. There is no choice here for me. When you say that homosexuality is an acquired habit and "like any habit it can be broken," you are denying volumes of respected psychological and biological studies which, while offering differing explanations, point out that homosexuality is a phenomenon beyond conscious control. To defend yourself, you cite nothing but your own ignorant, uninformed beliefs. Even in the dark ages, when the American Psychiatric Association still listed homosexuality as a disease, that in itself was an acknowledgement that being gay was more than a willful decision. Thankfully, the APA too has come to realize that we are representatives of nothing more than an alternate, equally legitimate, lifestyle.

Gay people do not choose to have gay feelings. They do make a choice, however, when it comes to accepting their gay feelings, and telling the world that they are gay. Need I continue to repress my innermost emotions, lying to myself and being frustrated and unhappy

for the remainder of my life, or should I embrace my feelings and accept them as an integral part of me? I have chosen to come out, to acknowledge my identity and to stop hiding it from the world. It is a continuing, life-long process; I am just beginning. In all frankness, I am scared — scared because in this world there are many people like you, Mr. Milliron, who teach that homosexuality is evil and who seek to deny us our human rights and dignity.

In your letter, you challenged me to examine my life to see if I had made a conscious decision to be gay. This letter is my answer. Now, I challenge you to make a choice. You can cling to your baseless opinions or you can reach out to the gay people around you and try to understand. Just open up your eyes and you will see them. They need your support, not your condemnation.

Name withheld by request

No more conversion therapy for gays

To the Editor:

Mr. Daniel Milliron's letter instructing us that homosexuality is a bad habit is so naive as to be laughable. But it illustrates so well the sort of murderous, ignorant prejudice that gay people face that it must be answered.

People who find themselves to be occasionally or exclusively gay (the reasons are unknown) inevitably are at odds with the society around them. They must accommodate, and that accommodation is inevitably difficult. Some do it smoothly, some have protracted problems, some never really manage. The support systems are too often tenuous, and the opprobrium which we face is constant. But the sexual preference is also constant. Gays often move — flee — to certain large cities, such as Boston, precisely because the primary support system of a gay community ("ghetto") may be found there. Those who would decry the effect of such a presence should examine their evidence more carefully. The contributions of gay people to Boston's salubrious environment are considerable. And our gayness is a significant

Scientific evidence on gays

To the Editor:

Daniel Milliron's recent letter to *The Tech* ("Homosexuality is an Acquired Habit," *The Tech*, 5/8/81) contains a curious mixture of confusion and misinformation.

I'm concerned that an MIT student should feel so free to ignore over 30 years of scientific research into the nature of homosexuality, substituting instead his uninformed "opinion." Milliron is welcome to present his opinion on policy questions regarding homosexuality (i.e.: Should homosexuality be grounds for discrimination in employment?), but as to the facts regarding its nature, he might be modest enough to defer to those with some professional experience or training.

Milliron suggests that gay people are those for whom homosexuality has become a habit. There is increasing agreement among sex researchers, however, that a person's sexual orientation is

determined long before puberty, perhaps even before one reaches kindergarten age. Would Milliron want us to give his opinion the same weight we give to the vast body of scientific research into homosexuality?

If homosexuality is an acquired habit, what an irresistible habit it must be. People risk losing their parent's love, their jobs, their security clearances, their friends; all to satisfy this one habit. They (sometimes) seek psychiatric treatment to be rid of it, (sometimes) seek to crush it under the weight of a heterosexual marriage, (sometimes) even succeed in breaking the habit by taking their own lives. All this despite the obvious and "natural" alternative of heterosexuality. Honestly: is heterosexuality so awful, or homosexuality so incomparable, that mere experimentation with gay sex leads people to risk losing their jobs and homes to live out their habit?

Perhaps Milliron is confusing homosexual acts with homosexuality. Alfred Kinsey, in his now-classic study, "Sexual Behavior in the Human Male," reported that nearly half of all American males fell somewhere between "exclusively heterosexual" and "ex-

clusively homosexual" behavior patterns, and that only about ten percent were "exclusively homosexual" for a sustained period. Certainly a great deal of experimentation with gay sex goes on between persons who later discover themselves to be predominantly or exclusively heterosexual. This does not mean that these persons have escaped or broken the habit of homosexuality; it means they have discovered their own heterosexual natures. Some people are just like that.

I am gay, and I definitely have no desire to "kick the habit." I am grateful that I'm able to love other men, and grateful that I can cement that love with physical intimacy. I do have regrets about being gay, but they stem entirely from living in a time and place where my own nature leaves me open to harassment from bigots. Mr. Milliron's suggestions that I am unnatural and a victim of habit are less openly violent than some suggestions I've heard, but the underlying ignorance and hatred show through, and they are as ugly as usual. Mr. Milliron should clean up his act, and put love before hate.

Mitch Trachtenberg '78

factor in our presence, our personalities, and many of our career and life choices.

Any gay person who would repress or change his or her sexuality does so at his or her peril. But very few of us would; we have more common sense within our community by now. "Conversion" therapies, so fashionable in the 1950's and early 60's, still find their occasional odd advocate — some of whom have a desperate personal stake in trying to practice what they preach. They may achieve a certain repression of their natural personality, but this often results in an unreal relationship to the world around them — psychosis in an ordinary dictionary definition. The attitude of gays as a community, and of a broad spectrum of medical, psychological and religious personnel

(please turn to page 6)

SENIOR WEEK

TICKETS MUST BE PURCHASED FOR SENIORS ALSO.....

SENIORS: PLEASE TAKE NOTE.....

Many Parents have sent in ticket orders for two or four tickets to a particular event. We are not sure that all parents realize that tickets must be purchased for seniors also.

Please check with your parents to be sure that tickets have been ordered for all who expect to attend.

We still have some tickets left. If there is a problem, please send a note and/or check for additional tickets to Lynn Radlauer in McCormick Hall today!

There will be a meeting for people interested in planning Senior week on Thursday Mat 14 at 6pm in the UA Office, W20-401.

Get a memorable rate on Memorial Day.

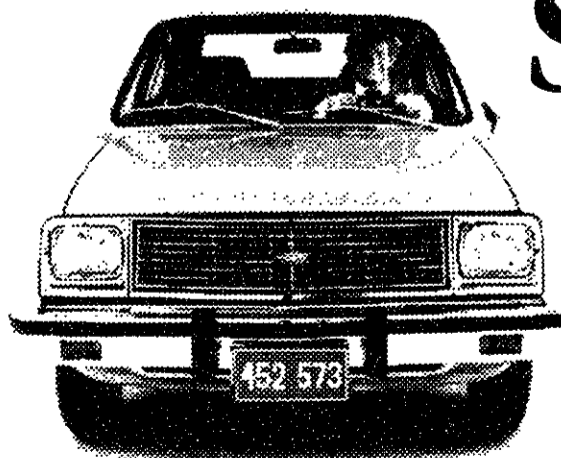

We feature GM cars like this Chevrolet Chevette.

\$79.80
4 DAYS
FREE MILEAGE

Here's a low rental rate that's too good to forget. You pay for gas and return car to renting location. Rate applies to car shown or similar-size car and is non-discountable. Specific cars subject to availability. Rate available Thursday noon (5-21-81) to Tuesday noon (5-26-81). Certain daily minimums apply.

National Car Rental

You deserve National attention.™

Available at:

183 Dartmouth St., Boston, Mass. 426-6830
1663 Massachusetts Ave., Cambridge, Massachusetts 661-8747

NEED HELP WRITING YOUR RESUME?

Let me save you time and energy. You'll like the results. Professionally done for \$20. CALL 226-5530 or 335-9508

Temporary Staff Assistant Position in UROP Office. Full-time for approx. 6 weeks starting roughly July 24. (35 hrs./wk. + \$6.00/hr.) Will perform variety of secretarial duties for busy program under supervision of UROP staff. Will answer phones, type, xerox, file, and other duties as assigned. Requires excellent typing & good interpersonal skills. Contact Susan Mitchell-Hardt, 20B-141, x3-5049.

PRE-MEDS/ PRE-VETS

Candidates for study leading to degrees in both Medical and Veterinary Medicine can now combine:

- One year (36 credits) toward accredited M.S. program at major Universities.
- Completion of program toward Medical or Veterinary Medicine degree in a Caribbean or European school.

Now accepting applications for July and November semesters. For interview call: (203) 661-8906.

CENTER for the DEVELOPMENT of INTERNATIONAL POST GRADUATE STUDIES
two sound view drive, greenwich, connecticut 06830

Many social pressures plague gays

(continued from page 5)

is more than ever that of helping people troubled by their sexuality to adjust to their innate condition, be it exclusively straight, exclusively gay, or something in between.

The social pressures that give rise to Mr. Milliron's attitudes, to "conversion" therapies, to damaged GAMIT notice boards, to bashed queers, and a thousand other atrocities are a subject for a lifetime study. Those of us who are gay will study those pressures out of self defense, as well as curiosity. I hope Mr. Milliron will eventually grow up to undertake at least a brief study of such things — just lengthy enough to give him an idea of the limits of his learning and the vastness and arrogance of his ignorance. I would suggest he visit the GAMIT lounge (50-356), to talk with some ordinary people whom he can know are gay (he talks with some of us every day already). I would suggest he read C. A. Tripp's *The Homosexual Matrix*. It contains an interesting chapter entitled "The Origins of Homosexuality." That is preceded by a chapter entitled "The Origins of Heterosexuality."

Straight people are perpetually curious, scared or antagonistic (or some combination thereof) about

gayness. Sometimes it surfaces in ugly ways. The head of the present exchange was the Pi Lambda Phi incident. Let it be said to the fraternity's credit that, in a badly besieged condition, they have responded with very real attempts to understand gay people (and, I think, themselves) better than they presently do. I hope their example will be followed by others.

Mr. Milliron's letter was an interestingly juxtaposed under Rabbi Shevitz's letter reminding us that the MIT community is presently "struggling . . . with bigots of every stripe." Mr. Milliron '84 is probably still too young to be labelled a real-live bigot, but he is sufficiently naive

to be one. His personal belief that heterosexuality is natural is an insufficient reason for me to change my innate (not "habitual") condition. In an academic environment less humane than MIT's (almost all are), this letter would be quite ill-advised. Fortunately, the Institute encourages such exchanges as a vital part of the educational process. I hope that, in the next three years, Mr. Milliron will use this educational process well enough to begin to understand both my innate condition, and his, better than he presently does; and why he can sign his name freely, but I must think carefully before signing mine.

Nicholas Altenbernd

Editorials, which are marked as such and printed in a distinctive format, represent the official opinion of *The Tech*. They are written by the Editorial Board, which consists of the chairman, editor-in-chief, managing editor, and news editors.

Columns are usually written by members of *The Tech* staff and represent the opinion of the author only, not necessarily that of the rest of the staff.

Letters to the Editor are written by members of the MIT community and represent the opinion of the writer.

The Tech will attempt to publish all letters received, and will consider columns or stories. All submissions should be typed, preferably triple spaced, on a 57-character line. Unsigned letters will not be printed. Authors' names will be withheld upon request.

Disarmament may not bring peace or freedom

(continued from page 4)

the ideals and needs of stronger nations, and is that peace and freedom? The Russian invasion of Afghanistan and possible invasion of Poland are prime examples. Does anyone really believe that if we disarm we would be free and able to live in peace? I'll bet the people who scream and cry about disarmament would have the toughest time swallowing communism.

Therefore, the best way to maintain peace is to deter war, and this is accomplished by maintaining a strong military force. However, this does not license us

to exert our military force on weaker nations because they do not hold the same views as us. A strong military force is also needed to protect our national interests. An example of this would be World War II. If our country had not had a strong fighting machine during that time, Europe surely would have been overrun, and the fall of the US to the "master race" would have been inevitable. Now, I don't know about everyone else, but I never did like the mass purgation of people.

Patrick Robertson '83

classified advertising

JEEPS, CARS, TRUCKS

available thru government agencies in your area. Many sell for under \$200.00. Call 602-941-8014 Ext. 6533 for your directory on how to purchase.

PROFESSIONAL TYPING

STAT., TECH., GENERAL 24 hour service. Call Margie or Christine 646-4101.

GRADUATION CONGRATULATIONS

Kim K. Hobgood

ASTHMATICS WANTED

for medical research on their disease. Stipend arranged. Call Dr. Griffin or Dr. Weiss 732-7420 Weekdays 9-5.

MOVERS

Local, Long Distance, Overseas. No job too small — low rates. Fast service, insured, call anytime. Weekly trips: NY, NJ, PA, DC, VA.
Finnegan — 364-1927

The Cambridge Food Co-op



Wide Selection, Low Prices
"FOOD FOR PEOPLE,
NOT FOR PROFIT"
580 Mass Ave., Central Sq.
Under Singer 661-1580

KEEZERS HARVARD COMMUNITY EXCHANGE

Our formal wear department has a full selection of second hand white dinner jackets in a full range of sizes. You can own a tuxedo for the cost of rental.

221 Concord Ave.
Corner Huron Ave.
Cambridge
547-2455 MIT

REFRESHER COURSE.

You've burned the midnight oil and cracked more books than you care to remember. The work is done. The papers are in. So now you take a refresher course. The subject: ice cold Dos Equis beer. The Uncommon Import. Study a frosty glass. You'll learn it has a

rich, amber color unlike any beer. Now test that big, bold flavor. You've got to admit, Dos Equis is in a class all by itself.

DOS EQUIS
THE UNCOMMON IMPORT
Amber and Special Lager

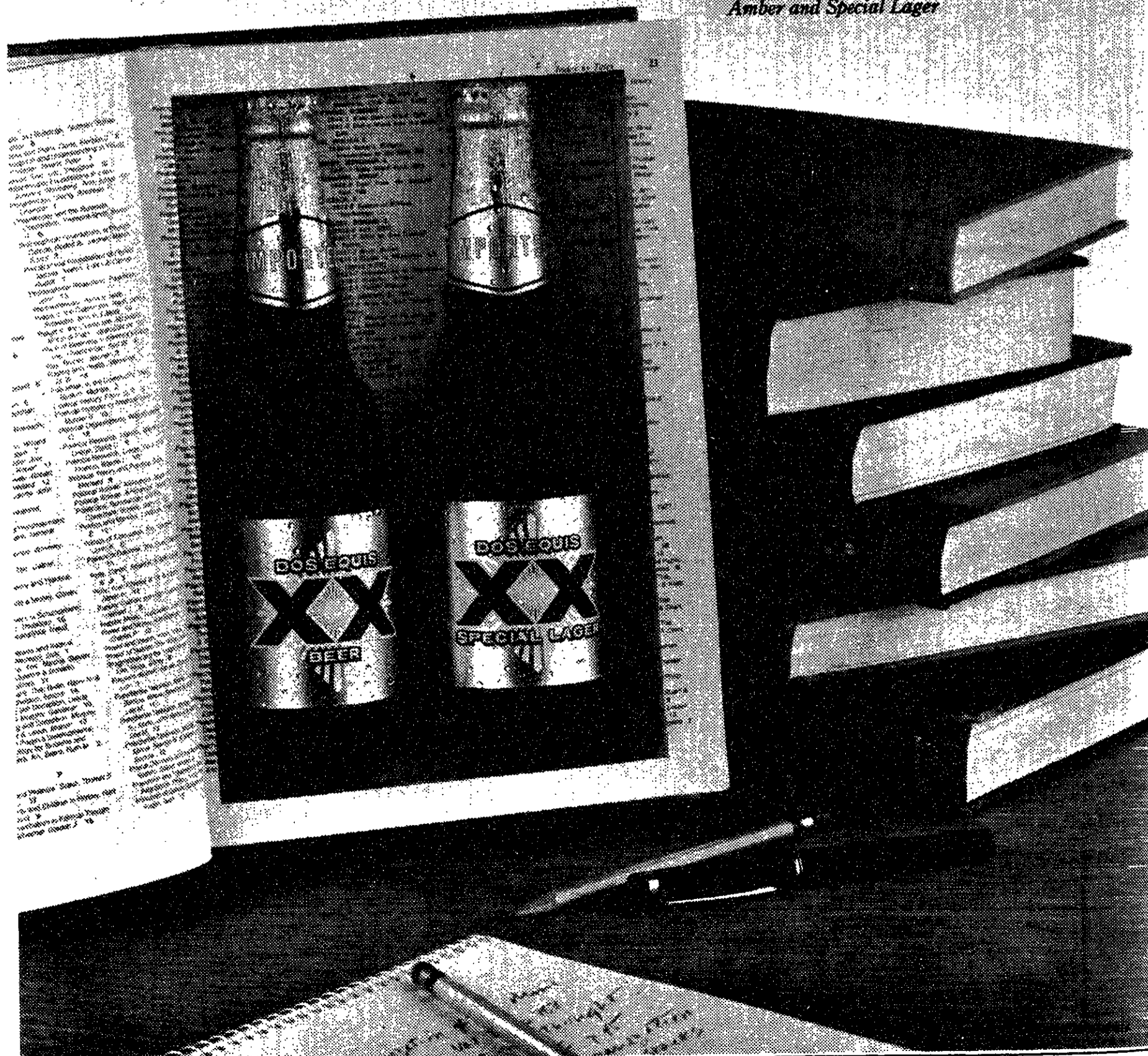

PARTS

查尔斯河畔的音乐会

Mary Chung Restaurant, 447 Mass. Ave., Cambridge, 11:30-9:45 Sunday to Thursday, 11:30-10:45 Friday and Saturday, take-out service, 864-1991.

Those who love Chinese food must be overdosing in Central Square these days. My bet is that they will take their habit somewhere other than the Mary Chung Restaurant.

Mary Chung replaced the now defunct Joy Fong. You wouldn't know it from the decor, however. The overwhelming feeling one gets on entering the restaurant is that Joy Fong just changed her name.

The food dispels all such thoughts. The selection is... interesting. There are many dishes that aren't found in the other Central China Sea of restaurants. Moo shi dishes with Peking sweet bean paste and hot and sour soup with wontons are typical examples.

Unfortunately, the taste is as unexciting as the selection is interesting. The orange sauce on the orange sauce chicken is bland at best. The kung pao chi ding (spicy chicken with peanuts) has more of a stale aftertaste than a spicy kick. Moo shi with bean paste is not worth the trouble, and the sweet and sour pork is more sour than sweet.

The hot and sour soup with wontons is a surprising exception. It is not fantastic, but it is a variation of the typical hot and sour soup. It is not worth suffering through the meal that follows, however.

Worse than the food is the service. Few of the help understand English, or even international sign language. If the main dish came any sooner, it would have arrived before the soup. The bill and fortune cookies follow very close behind the main dishes.

The help has obviously been informed that the water glasses are to be kept full, a job they pursue with unequalled enthusiasm no matter who or what might be in the way. Empty plates and dishes fly away before the stunned diner can set them down. One waitress even cleared the table before the meal was served thinking the meal to be over.

If you are thinking about a Chinese dinner, stop in at Mary Chung's for soup... and then go somewhere else.

Gordon Hunter

In The Congo

Psychedelic Jungle, the Cramps on IRS Records.

And they aren't kidding. I got worried when the Cramps, one of the most ultimately American phenomena we have the rights to, lost their guitarist, Bryan Gregory, to some San Francisco black-mass cultists (yes, yes, yes). Gregory personified the cool-trash ethic of the Cramps the way no one else could, and the records they cut with him are such stuff as rock n' roll dreams are made of. Cramps albums are a modern-day, direct-line connection to the days when America was groovy and crazy and bands like the Del-Vets were doing "I Call My Baby STP" while kids writhed around on the floor.

The Cramps hit the stage, any stage, with an evil hiss of electric guitar, performed by candlelight, and have every "Psychotic Reaction" reference at their fingertips. No bass, two guitars (Gregory and the gorgeous Poison Ivy, the coolest woman in Rock and Roll), Nick Knox's drums, and Lux Interior's quavery vocals were the Cramps' sound. Gregory's been replaced by Congo Powers (I told you they weren't kidding) and the Cramps have moved from fuzzbox vehemence to really psychedelic territory.

The sound still grinds along and threatens to crush in your eardrums (e.g., "The Crusher"), but there's a new spookiness in their sound, songs like "Voodoo Idol" and "Can't Find My Mind" and above all "The Green Door" (which WBCN dares to play!) that toy with psychedelia like never before. Lux Interior hasn't given up his stance, but when he intones lines like "What I get free/You have to buy/I'm proud of my life/But don't ask me why," its got that Jim Morrison-cosmic-significance edge.

Things haven't slowed down stylistically — "Jungle Hop" pounds along with all the rockabilly, bubblegum violence of old Cramps material — but everything is geared towards the psychedelia mystique and away from the acid punk legend. Psychedelic Jungle couldn't have been more aptly titled: to the Congo and back again, surfin' safari buffs.

Sheena

Symphony Mods Out!

Surprise! Bet you thought I didn't pay any attention to classical music. Wrong again — nothing short of a Sex Pistols reunion would have kept me from last weekend's MIT Symphony concert. Not only did they perform some of the classic warhorses, but they added (as part of the Prelude series) a major new avant-garde work to the program — Steve Reich's *Octet*.

Having attended the New York premiere of the *Octet*, I was eager to see how well our own musicians would fare with this extremely difficult work. After the first three minutes (by which time the players relaxed) the piece came off rather well. At times the flutes became too loud in their higher register, at other points the strings weren't loud enough, and the tempo was slowed in order to accommodate the pianists (who had to cope with one of the most difficult parts in the modern repertoire). However, all these criticisms become secondary to conductor Neal Stulberg's innovative choice of a recent work by an important new composer — bravo! I hope that the performance of new music becomes a Symphony policy — perhaps next year at this time Kresge will reverberate to the strains of *Music for Mallet Instruments, Voices, and Organ*.

David Shaw

To conclude, the orchestra gave an exhilarating performance of Moussorgsky's *Pictures From an Exhibition*. Maybe all was not absolutely perfect, but the spirit was clearly there and overwhelmed any minor errors. There were many memorable moments: the quiet of "The Old Castle," the simultaneous power and melancholy of "The Oxcart," the humor and lightness of the "Ballet of the Unhatched Chicks." Fine vibrato in the strings gave an atmosphere of mystery to "Cum Mortuis in Lingua Mortua;" the build-up of fire in "Baba-Yaga" was breathtaking, dashing rhythms in the percussion perfectly timed to glorify the immaculate bowing of the strings. An imperious "Great Gate of Kiev" brought the piece to an exciting yet controlled end and rapturous applause, well-deserved by our marvellous Symphony Orchestra.

Neal Stulberg, in whose hands the orchestra has rested this year, has brought about a massive improvement during his tenure, not least in giving identity and discipline to all sections of the orchestra. I have been told by members of the orchestra that they have enjoyed working with Mr. Stulberg, regard him as a major asset, and want him to stay on; I would endorse that sentiment.

Jonathan Richmond



Saturday evening's MIT Symphony Orchestra concert began with Bach's *Concerto in D Minor for two Violins* with two MIT students, Arthur Hu and David McCall, as soloists. The orchestra provided a unified matrix of sound, a discrete building block upon which the soloists were polarized. The sound might have been filled out by the addition of a few more strings, while at the same time a plainer style of playing might have been adopted, though the method chosen was quite acceptable.

Arthur Hu developed a beautiful, seemingly effortless legato that came across with a spellbinding fluidity and richness of tone. David McCall, while doubtless making a valiant effort, was unfortunately not Mr. Hu's equal; his playing possessed a tense nervousness and sharp, disjointed roughness clearly at odds with the music.

Debussy's *Prelude a l'apres-midi d'un laune* came across as a breath of fresh air. In a slow, studied, intense rendition, a bouquet of orchestral color was developed. Flute solos, though perhaps a bit sentimental, were deliciously performed: unpushed, seemingly wafting by like a cooling breeze. Strings were well-disciplined, their airy sound now shimmering, now wandering lazily as on a carefree summer's day. The effect of staccato was of a stone plopping into a still lake, momentary suspense in a milieu of calm and serene bliss.

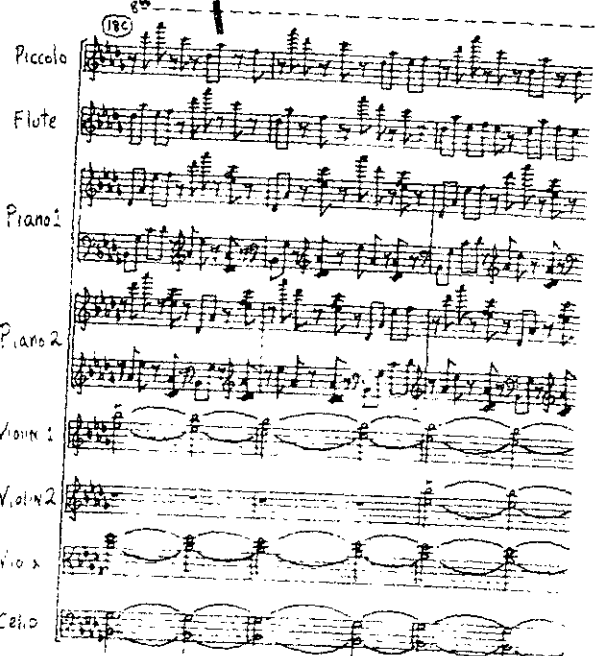
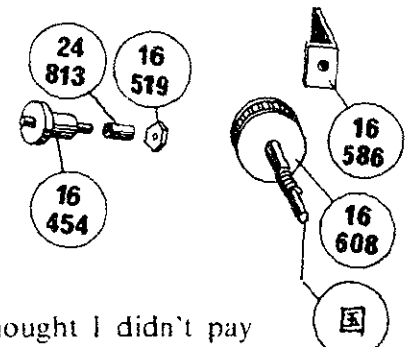
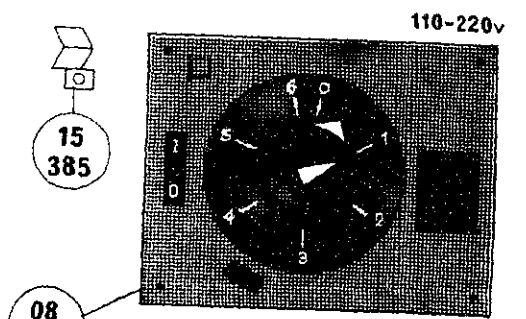
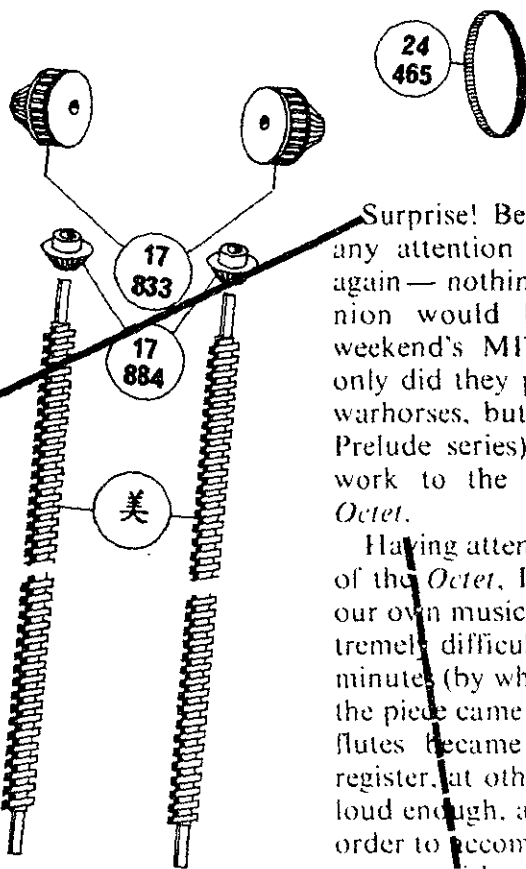
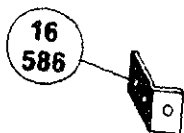
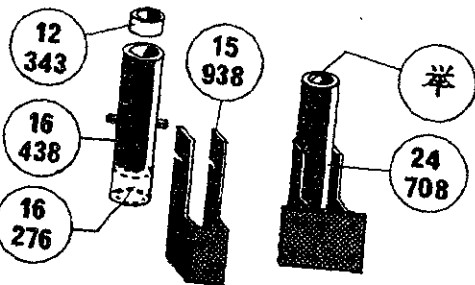
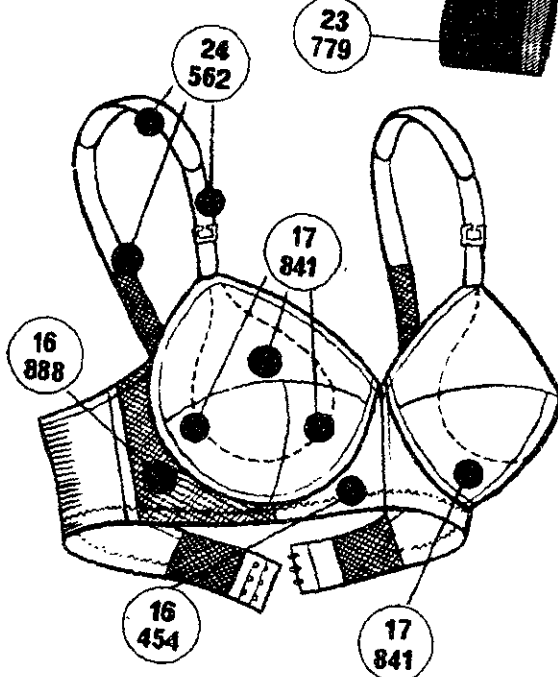
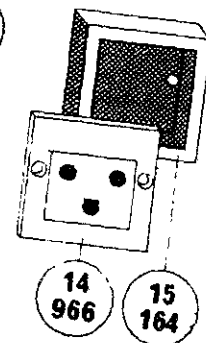
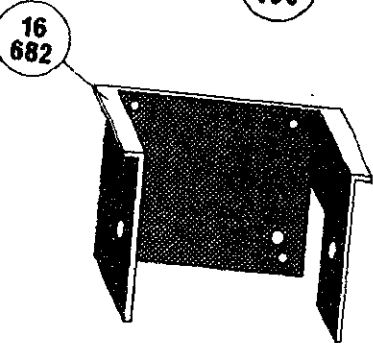
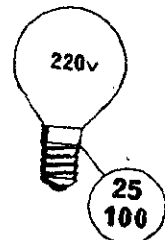
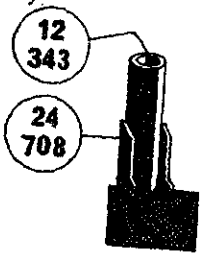
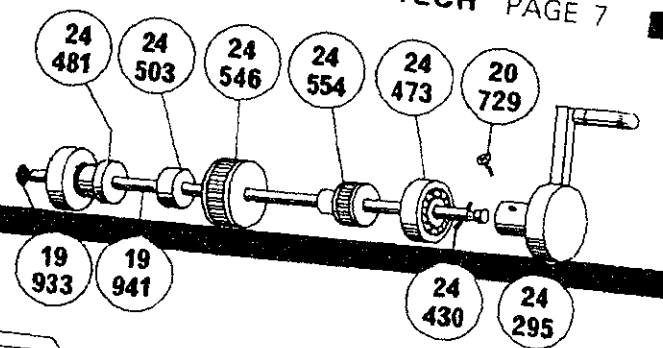
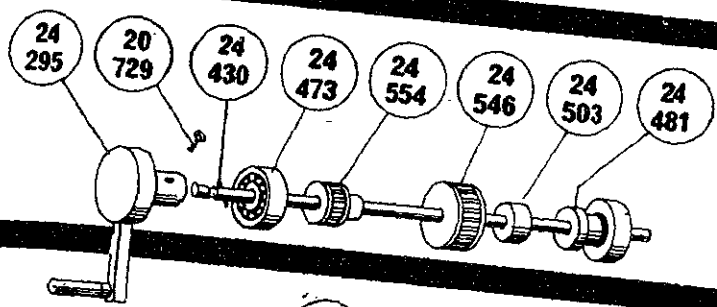
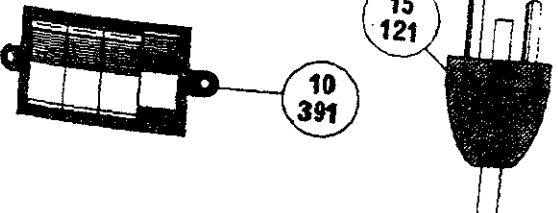
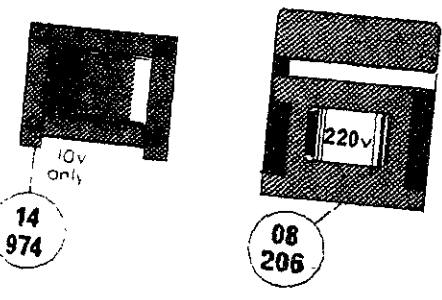

Graphic by Jon von Zeilowitz

MIT alum named to top NASA post

By Jack Link

Following last month's successful orbital test of the space shuttle, and the departure of veteran space officials, President Reagan has nominated Hans Mark '54 to the post of deputy administrator of the National Aeronautics and Space Administration (NASA). Congress is expected to approve the nomination without opposition.

"They'd have been hard pressed to do better under the Reagan Administration," said Professor Herbert S. Bridge, Director of MIT's Center for Space Research.

"They could've picked a lot worse."

Mark, who received his degree in physics from MIT, was Secretary of the Air Force under President Carter. Prior to that, he spent 11 years as director of NASA's Ames Research Center in Mountain View, California.

"They had a solid program in basic research while he was at Ames, though I wouldn't say that the amount of science done there while he was director went up," said Bridge.

Bridge did not appear to be concerned about Mark's past role

as Air Force Secretary. "I think it's extremely desirable to have the civilian and military operations in space cleanly separated, but without the Air Force, the shuttle would've been cancelled."

Bridge pointed out that most space science projects now depend on the shuttle since the nation has lost the capability to produce large, expendable rocket boosters. "Given Mark's background, I'd say it's a good sign for science," said Bridge.

Bridge also offered his speculation that the "Reagan Administration will move more in the direction of some large project in space. There's talk about a space station."

Advisor to be named

By Frank Hrach

The Reagan Administration is expected to name a 41-year-old nuclear physicist to the post of science advisor to President Reagan.

The physicist, Dr. George A. Keyworth, works at the Los Alamos National Laboratory in Los Alamos, New Mexico. He is less well-known than some of his predecessors, including the last presidential science advisor, Frank Press, MIT Professor of Earth and Planetary Sciences.

The Reagan Administration had a difficult time finding a presidential science advisor, since they initially expressed doubts that the post even needed to be filled. This caused many prominent

scientists who were considered for the job to reject the post.

Keyworth is head of the Physics Division of the Los Alamos Laboratory. He directs the work of over 500 scientists and technicians, but he has little experience in national science policy.

Keyworth has worked the last 13 years at Los Alamos, which is supervised by the Department of Energy, and has worked on nuclear weapons physics, laser fusion, and basic nuclear fusion research.

He is widely expected to increase in the science advisor's role in military policy with his background.

Dickson to co-ordinate administrative operations

By Stephanie Pollack

Vice President for Operations William R. Dickson '56 has been asked to co-ordinate the administrative operational duties of all the vice presidents, according to President Paul E. Gray '54.

Dickson will be the coordinator for all "management responsibilities on the academic side of the house," Gray added. He said the purpose of the change in administrative structure was "to bring these functions together short of the president."

Gray said the reorganization was "intended to reduce the amount of time I will have to spend on administrative matters but assure that I am involved when necessary." Gray noted that, in the past, any issue which cut across organizational lines had to be handled at the presidential

level.

Gray has also named Kathryn Lombardi as Executive Assistant to the President. Lombardi will also continue as Manager of Campus Information Services. Gray said that Lombardi's duties will be to "help me use my time better and deal with the myriad of requests for my time."

Dickson will co-ordinate some of the duties of Vice Presidents Stuart Cowen, Samuel Goldblith '40, Constantine Simonides '57, and Kenneth Wadleigh '43. Gray cited some examples of the areas Dickson would co-ordinate, including the accounting, auditing, and student financial services under Cowen's jurisdiction, the personnel office overseen by Simonides, and the medical department and registrar's office controlled by Wadleigh.

Press to head Academy

(continued from page 2)

tion's budget for central research. One answer he offered was "to find more neutral sponsors." He also expressed anxiety over protection of technological secrets and escalation of the arms race. Thorough understanding of the technological issues and options by both the public and leaders must be a goal for the NAS, remarked Wiesner. "The Academy has to represent and lead in the formation of these views," Wiesner said.

Press concluded the symposium with his reflections of MIT. "These last years were the most productive," Press remarked. He claimed that his department was interesting because of its "breadth, high caliber, nice

people, and classy students."

He thanked the administration and Corporation Emeriti Cecil H. Green '23 and Ida M. Green, as well as his colleagues who covered for him during his term as Science Advisor to President Carter. Press also expressed the importance of Wiesner to his career and his desire "to emulate" him.

Press offered his continued support of MIT. "I would like to feel a sense of connection and help in any way that I can," he said.

Press closed the afternoon with words of deep appreciation for MIT, noting, "This is my home institution, this is where I have blossomed, and if I have done anything, it is because of what MIT has done for me."

ANY U.S. BOOK IN PRINT
 ORDERED BY TELEPHONE
 DELIVERED DIRECTLY TO YOUR HOME OR OFFICE
 ALL MAJOR CREDIT CARDS ACCEPTED
 OUR 8TH YEAR WORLD WIDE
944-8060 / 7 DAY - 24 HOUR SERVICE
 COOPERATIVE BOOK SERVICE OF AMERICA, INTERNATIONAL
 Reading, Massachusetts 01867 U.S.A.

MIT Community Players present
WOYZECK
 by Georg Buchner
 Thurs. May 14 at 8:00 pm
 Fri. May 15 at 8:00 pm
 Sat. May 16 at 5:00 & 9:00 pm
 Tickets \$3.00 or \$2.50 w/MIT ID
 MIT Kresge Little Theatre
 Reservations: 492-9277

the Coop
 MIT STUDENT CENTER

save 25%
Clemco garment bag
26.99
 comp. value \$36

Clemco answers your carrying needs with style and convenience. Scotchguard canvas bag features two pouch pockets, inside strap and buckle, hangers, unbreakable ribbed-steel frame and dependable lock that made Clemco famous.

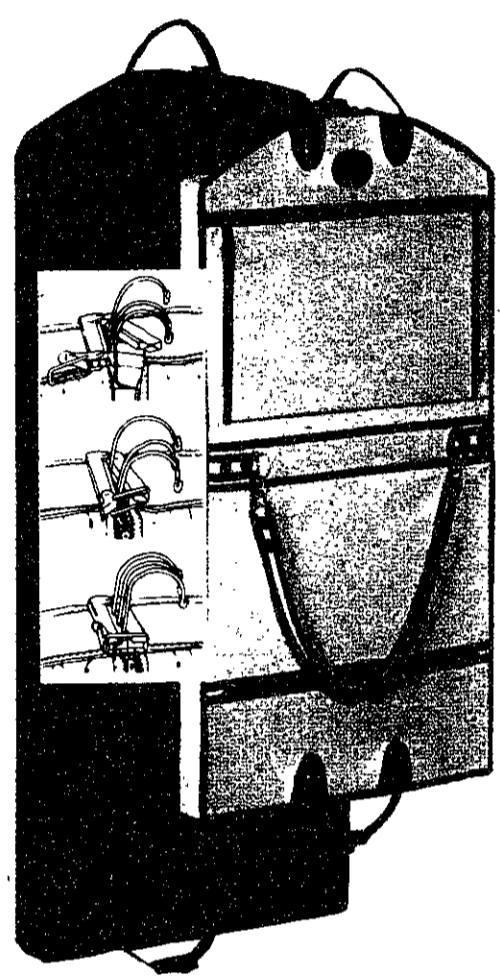

IT'S HERE.

technique 1981 is here.

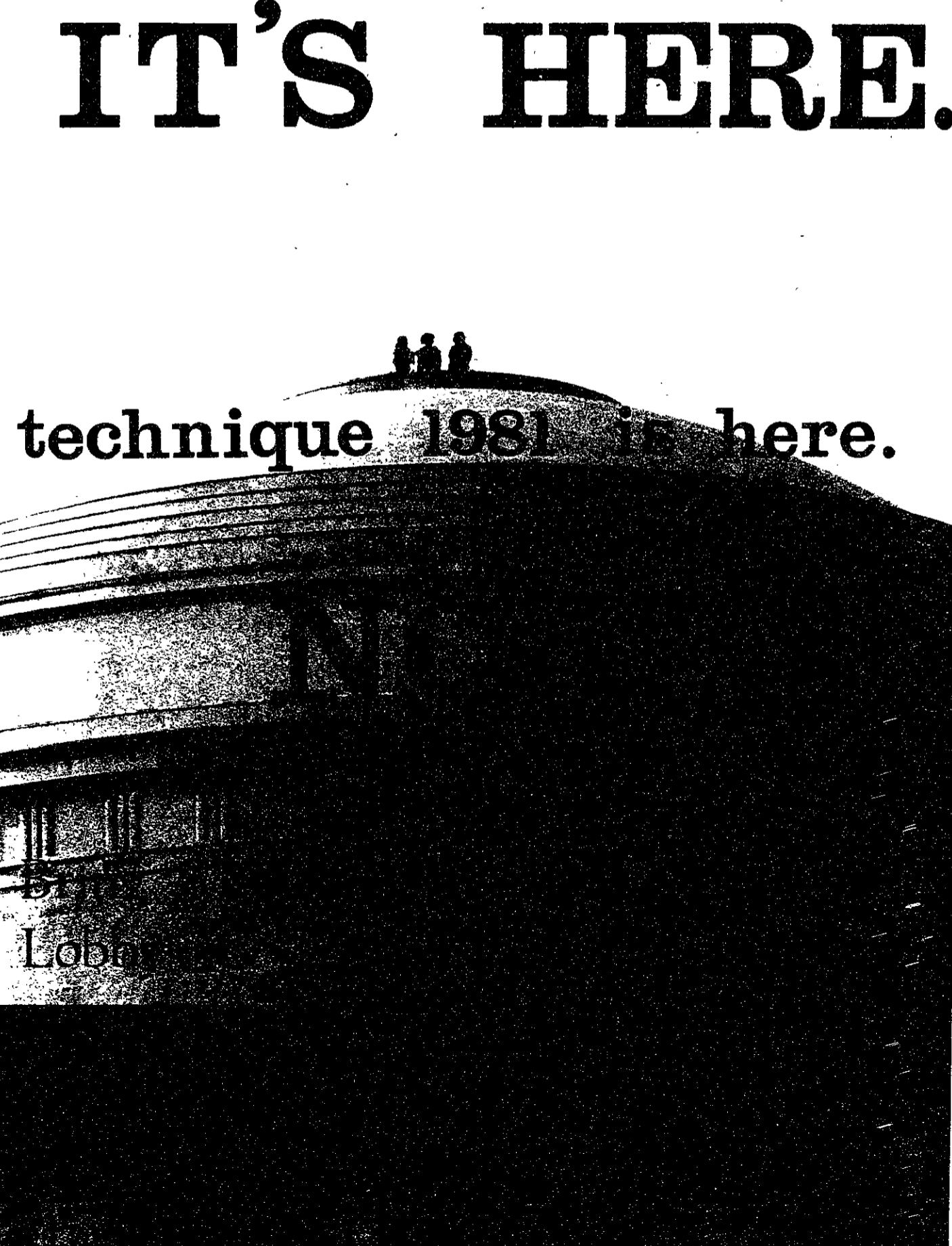

Loba

IMAGE
HAIR CUTTING
THE NATURAL LOOK
 wash & wear cuts for long and short hair

15% off
 with this AD
 offer good until 9/1/81

223 Newbury
536-1605

Bus stop poses security threat

(continued from page 3)

dicated Chernow, and ideas have included the Student Center, the Infirmary, Baker House, and Ashdown House.

Student response to next year's

change is somewhat ambivalent. "I can understand their [McCormick resident's] complaints," remarked Wellesley sophomore Karen Matz. "I'm indifferent," said Nick Nocerino '83, "it [Mc-

Cormick] seems to be the best lit place . . . If there's another place that's just as safe for the women who come from Wellesley, then it wouldn't make any difference to me."

Opinions voiced at DSA forum

(continued from page 1)

think it is totally absurd and obscene that we are here on a Friday night." Weller pointed out that non-students beside the Visiting Committee should not be permitted to attend future meetings of this type because "students are chicken."

Some students noted that the Dean's Office should be an advocate of student opinion. Weller said, "I believe the Dean is isolated from students, too isolated to present student's opinions correctly. What we have here is a dean of student affairs rather than a dean for student affairs."

Another broadly discussed topic was that of MIT's pace, especially that of the freshman year. Michael Lopez '83, said that students can spend eight hours a day on academic work. "As department requirements become stronger," he added, "students become dedicated to their major sooner. Talents and abilities aren't used. We have to sacrifice ourselves to leave early and save money."

Jack Link '83 raised the question of freshman pass/fail, saying that the evaluation system needed to be changed; when he was a

freshman, only half of his evaluation forms were returned from instructors. Carola Eisenberg, Dean of the Harvard Medical School and a member of the Visiting Committee, said that only Johns Hopkins Medical School requests MIT freshman grades. Harvard, she said, does not look at them.

Robert Feron, a senior in political science, complained about the freshman advisor system. He said that too many advisors encourage freshmen to get the core courses out of the way and "get a leg up in a

department." He added, "Unfortunately, this leaves out 'education.' A student can graduate without having had anything but his major. There should be a much more extensive consultation with student activity leaders as to what role the Dean should perform in this regard."

"One-third of the members of the Committee are corporation members, one-third are by appointment of the President, and one-third are members nominated by the Alumni Association," according to Weedon.

EYEOLASS & World

Complete Optical Shop

Fashion frames at reasonable prices

- Instant eye exams
- Prescriptions filled
- Fashion tints and photo changeables
- Contact Lenses 60 Day Trial
- Large Selection of Ray Ban Sunglasses
- Sport Frame Available

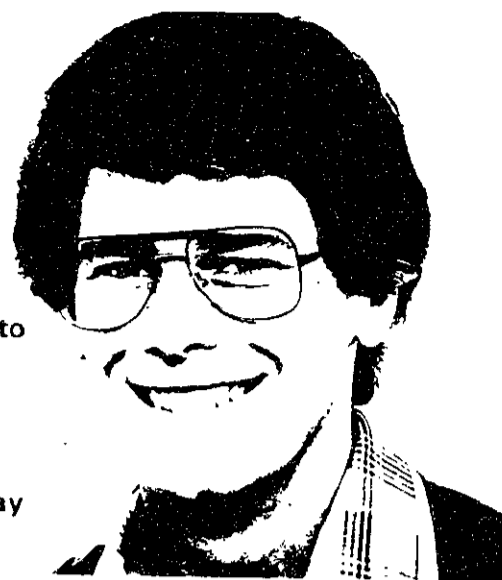

Central Square, 495 Massachusetts Avenue, Cambridge Mass. 02139 Tel: 661-2520

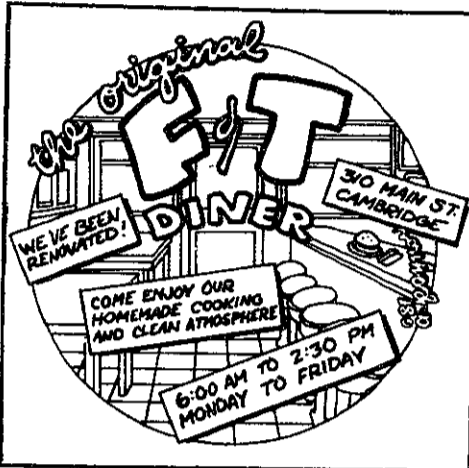

LEGAL AID

For legal advice at very reasonable rates call:

Esther J. Horwich, Esq.
MIT '77
227-6060

Suite 500, 44 School St.
Boston, MA 02108

TECH NIGHT AT THE POPS

The Boston Pops
Public Welcome

Thursday, June 4 8:00 PM



Tickets: \$13.00, \$12.00, \$10.00
\$7.00, \$5.00, and \$4.00 at
Building 10 lobby
May 11 - May 22
10 AM - 3 PM

Happy Birthday
Elaine Martel
on May 15th

from
all
of
us



UROP Office

Job Description: Part-time office help needed next fall, 10 hrs./wk. to assist with a variety of secretarial duties including typing, filing, xeroxing, etc. Pay is \$4.15 to start. MIT undergrads only, contact Susan Mitchell-Hardt, 20B-141, x3-5049.

L. G. Balfour Co. ANNOUNCES

CLASS RING DELIVERY DAYS

WEDNESDAY MAY 13

THURSDAY MAY 14

10-4

Lobby 10

Please bring balance due in order to pick up your ring

New orders also taken - 25⁰⁰ deposit.

Tell them you're proud — with a card from

American Greetings

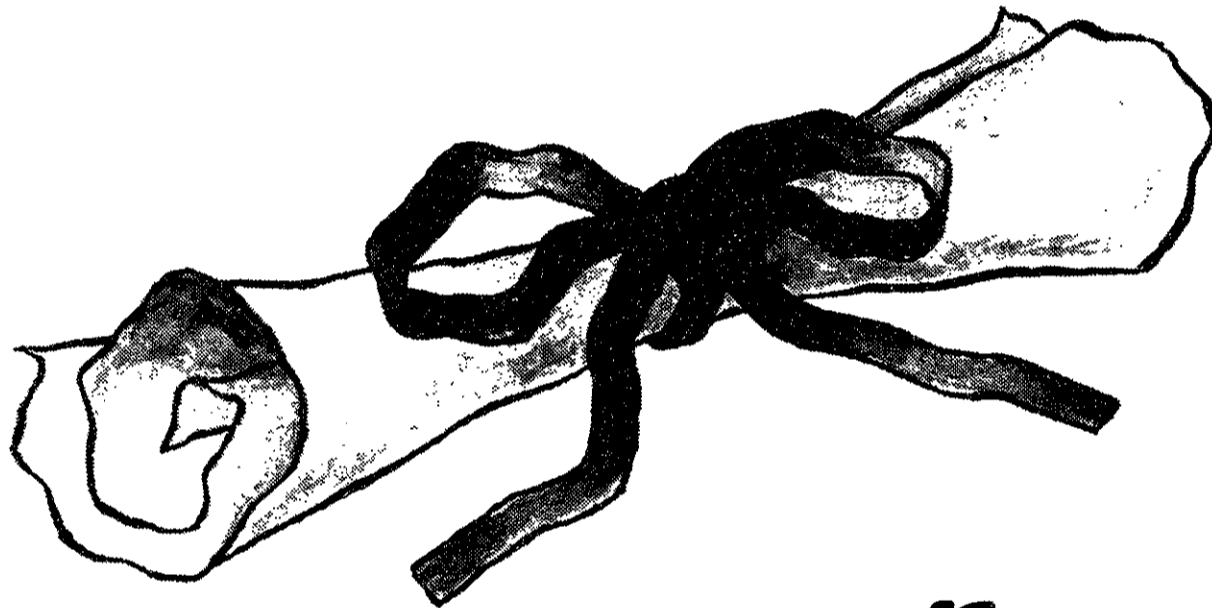

the Coop

MIT STUDENT CENTER

SCC and the 24-hour Coffeehouse

are pleased to announce their semi-annual

CAFFEINE SALE

Coffee and tea 10¢

from Wednesday May 13 to Wednesday May 20 from 7pm to 7am

with an MIT Student ID



THE TECH PHOTO CONTEST

1ST

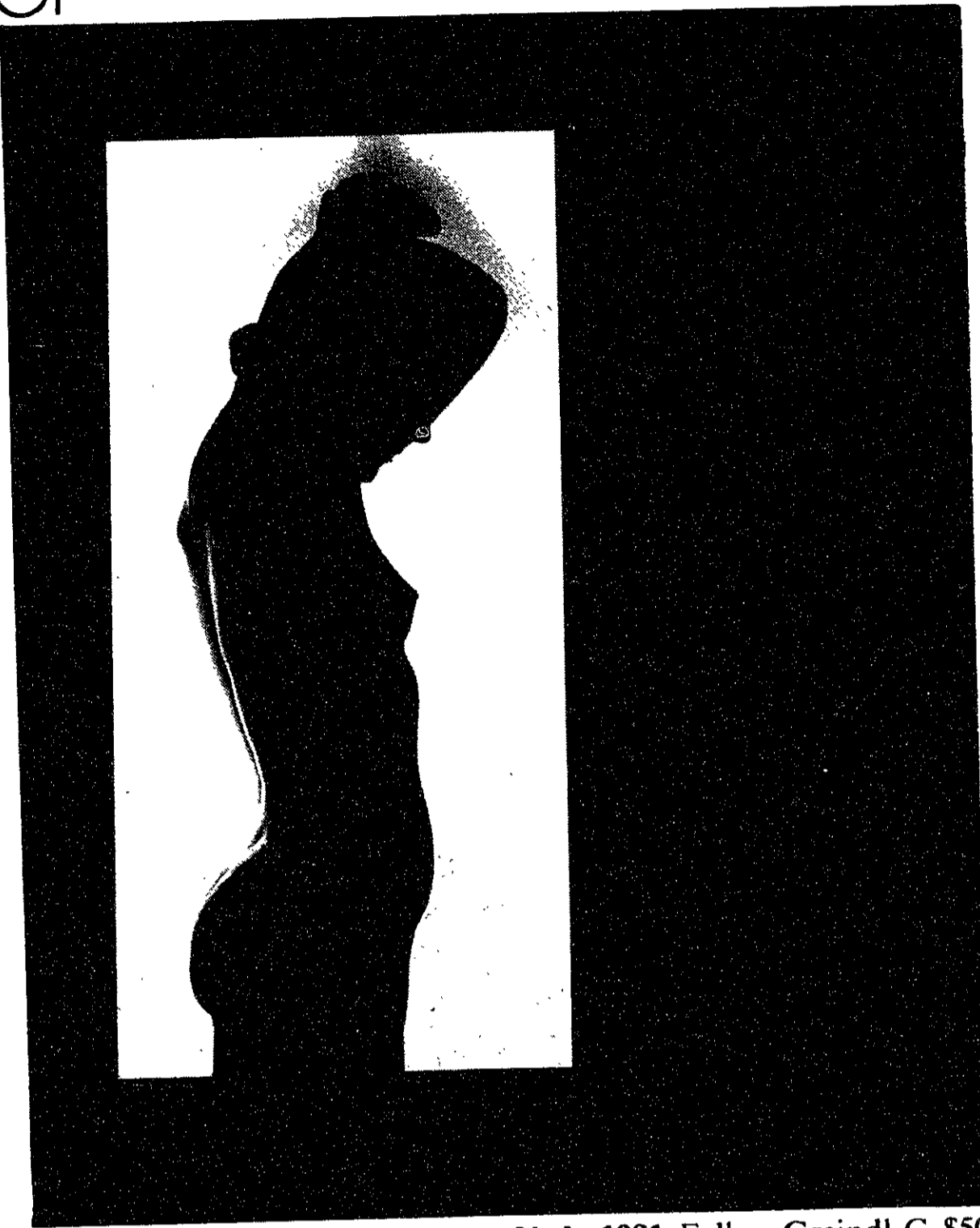

Nude 1981 Fallon Greindl G \$50

The Winners

STAFF



Untitled Jim Mihori '83

2ND

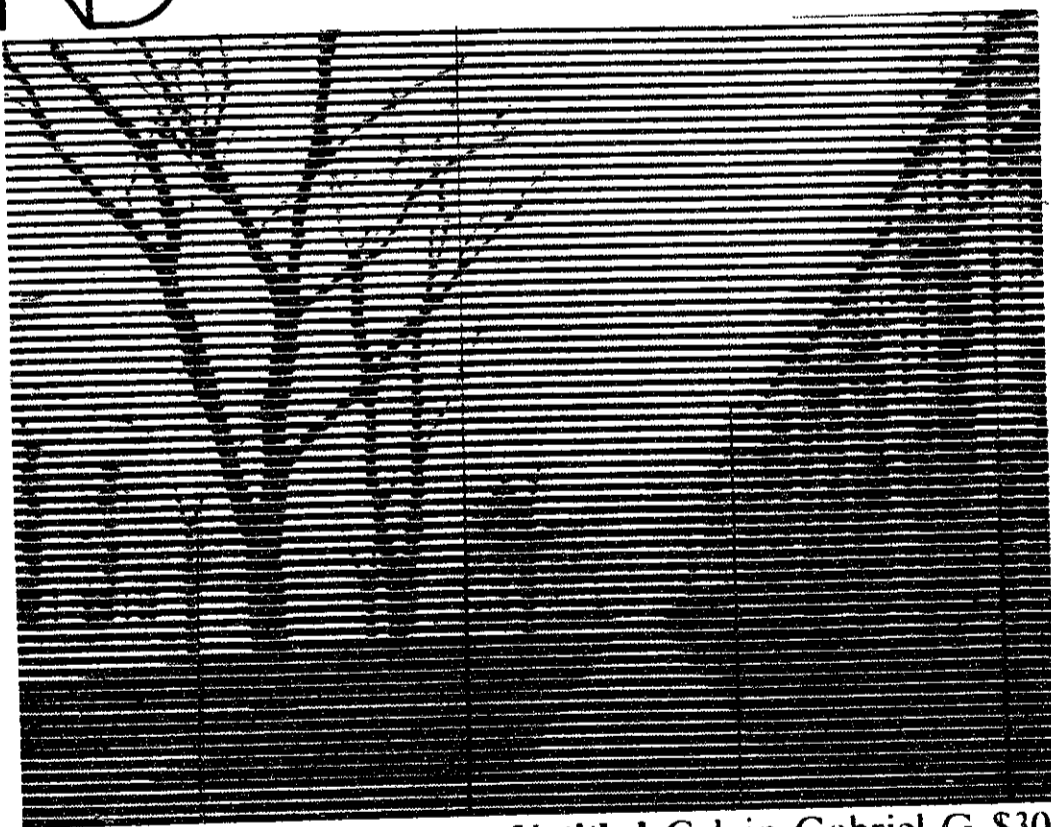

Untitled Calvin Gabriel G \$30

3RD

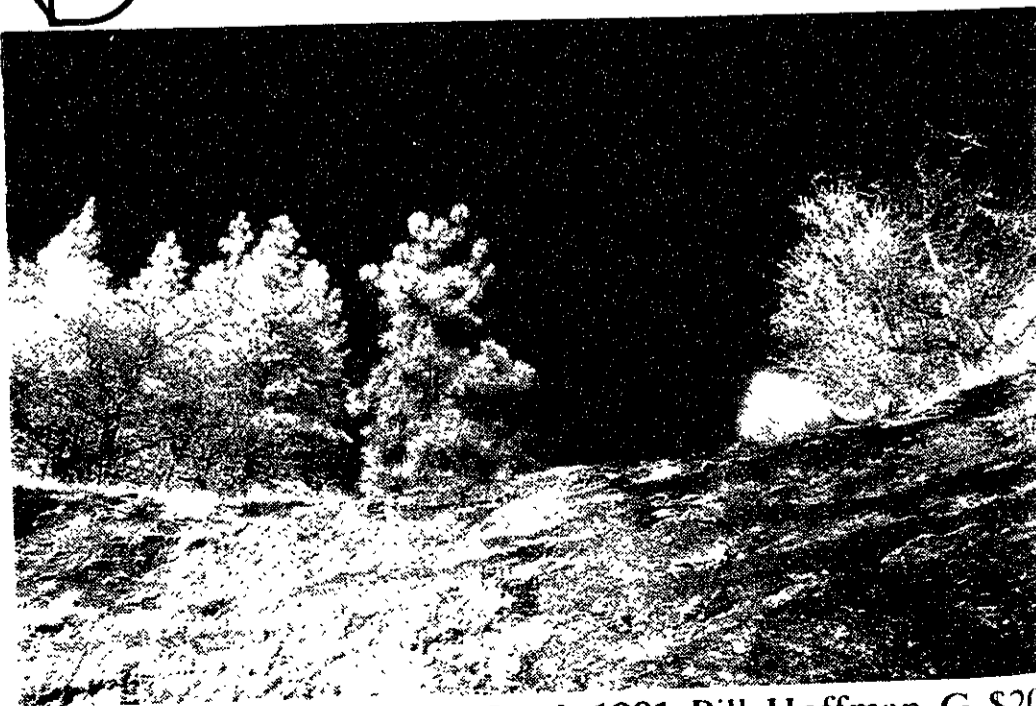

Kathy 1 - March 1981 Bill Hoffman G \$20

Thanks to all who entered with special gratitude to all who assisted with the contest. Contestants may pick up their photos in W20-483, or call us at x3-1541 and we'll mail them to you Interdepartmental.

UJAN NEWS

SUMMER CONTACT

The Summer Contact Program needs people to help contact the incoming freshmen of the Class of 1985. If you are interested, please call or drop by the UASO (253-6771, Rm 7-103) and leave your name, phone number, and summer address, if known. For more information, call Rob, 253-6771.

R/O EVENTS

If you are interested in managing the Lobby 7 Donut Stand starting in September, or if you wish to work a shift at the stand, please contact Art Vaseen at 536-1300.

DONUT STAND MANAGER

Order you Senior Almanac entries as soon as possible. Senior Week tickets will be available for pickup during the week of May 25 in the UA office (Room 401 of the Student Center) from 12-2 pm. Please bring your ID. For more information or if you would like to help, contact Lynn Radlauer 5-8613, or Mitchell Brook 5-6226.

SENIORS

R/O 1981

Would you like to be back at MIT R/O Week helping new students through orientation? Leave your name, address & phone number at UASO (Rm. 7-103). Questions? Call Rhonda Peck, R/O Coordinator, at 5-9688 or Cindy Pribble, R/O Manpower, at 3-3788.

WILL YOU BE HERE OVER THE SUMMER?

The 1983 Class Ring will be delivered on May 13 & 14 in Lobby 10. If you did not order a ring, you can do so then. All rings must be paid in full on the day you pick it up. Questions? Ask Ken Dumas (3-2696).

SOPHOMORE CLASS RING

Reagan is not going to help. For more information concerning the proposed Student Loan cuts, talk to your General Assembly member or Rhonda Peck & Eric Gold at 3-2696.

HOW ARE YOU GOING TO PAY FOR TUITION?

GOOD-BYE CLASS OF 1981

The Undergraduate Association would like to wish all graduating members of the Class of 1981 best wishes for a successful future.

FRESHMEN SUMMER PACKET

Each year the R/O Committee mails a packet to all freshmen with information flyers from student activities. (This mailing does not include living group information.) The cost is \$25 per 8 1/2 by 11 sheet in the packet. If your activity would like to be included in the packet, pick up an information sheet at 7-103, UASO. For more information, call Rhonda Peck, R/O Coordinator, at 5-9688 or Neal Lippman, R/O Packets, at 5-8390.

FRESHMEN SUMMER PACKET

The last "Preview" issue of the term was distributed Thursday, April 23. However, social events can be listed on "Partyline." Leave information in the SSC office (W20-347) or call 3-3916. The "Partyline" number is 3-3942.

PREVIEW

Mr. Stu
By Glen Appseloff

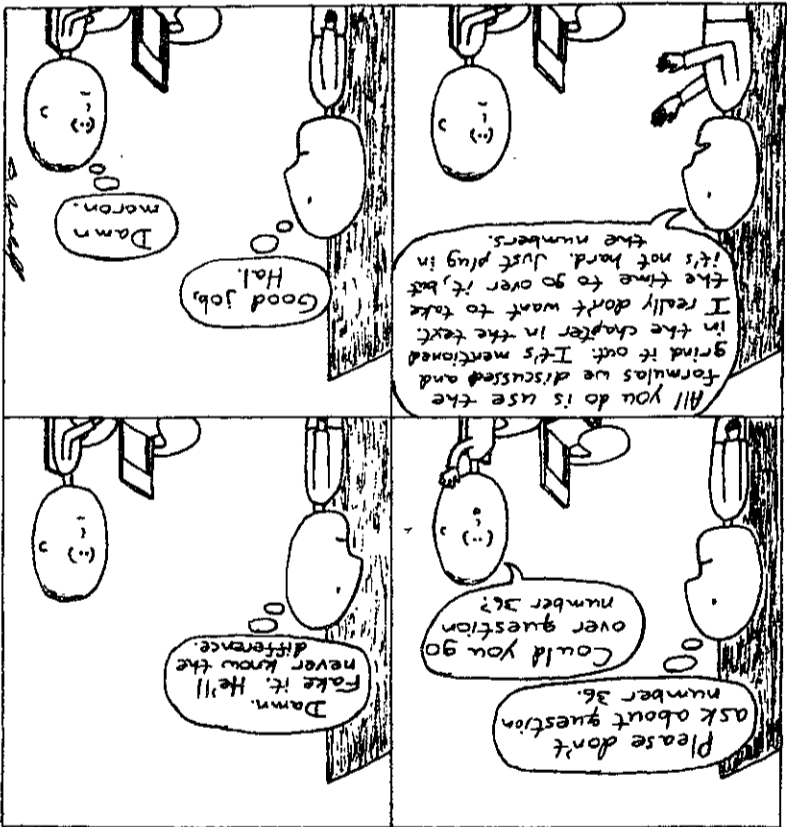

Stickers
By Geoff Baskir

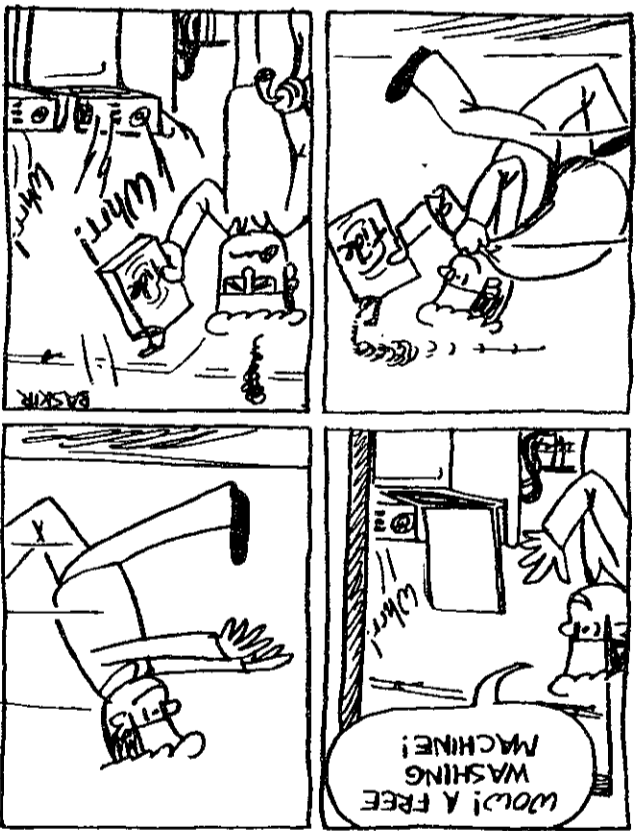

Outside Looking In
By V. Michael Bove

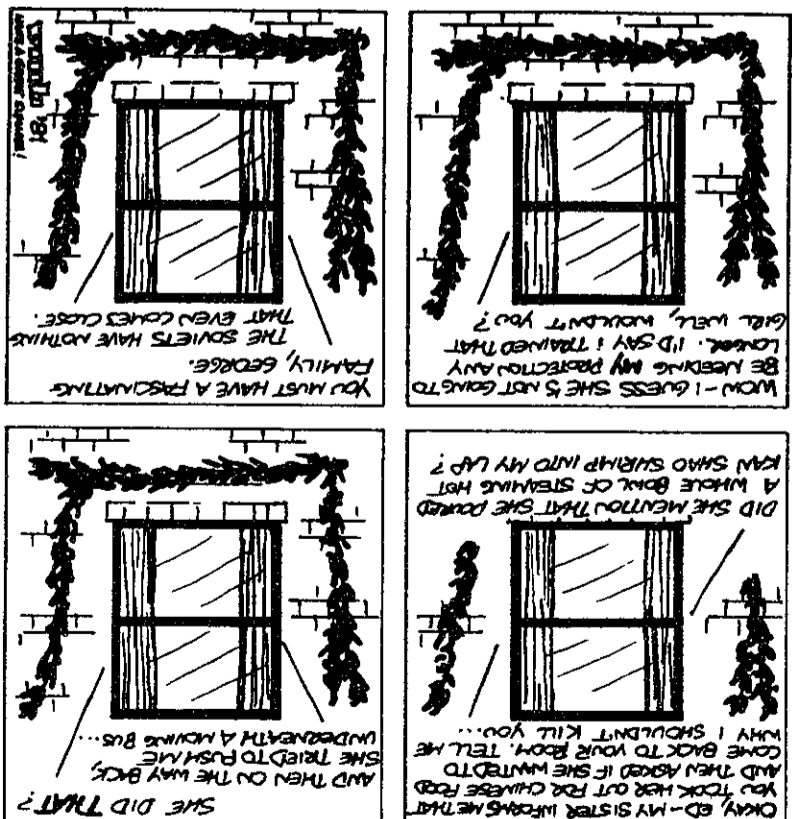

Space Epic
By Bill Spitzak

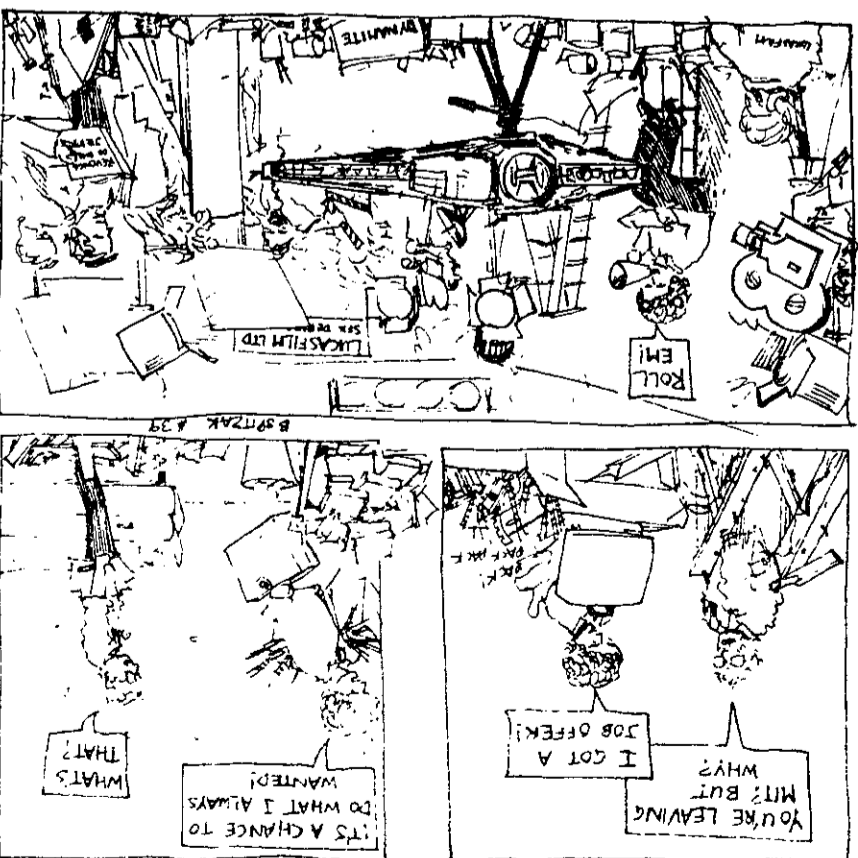

Top athletes awarded today

By Eric R. Fleming

Senior Bob Clarke heads a list of MIT student-athletes slated to receive major awards this afternoon in the Special Events Center.

Clarke led the men's basketball team to a 12-11 record, its second straight above-.500 year, and was one of the top players on the lacrosse squad that finished the spring at 7-6. Clarke leaves MIT with a total of 968 points and 765 rebounds during his four-year cage career. The Evanston, Illinois native is this year's recipient of the Class of 1948 Award, given to the senior who is selected Athlete-of-the-Year.

Another lacrosse player, goalie Adam Sapirstein, will receive the Cochrane Award for the senior who has demonstrated outstanding qualities of leadership and inspiration. Sapirstein is one of the nation's top goalies, with impressive statistics such as his .730 save percentage. Despite playing much of the season with knee problems, Sapirstein averaged 19.3 saves a game, including a season-high of 31

against Trinity.

The Scholar-Athlete-of-the-Year (Kispert) Award goes to Ed Marcus '81. Marcus, who resides in Wellesley, won his division in the New England Fall Sailing championships, and earned a third in the Boston Dinghy Club Cup, which featured 19 top squads from around the nation.

Erik Altman '83 is the Anderson Award winner for 1981, given to the manager-of-the-year. Altman has been manager of the cross country, indoor and outdoor track teams in his two years at MIT, in addition to having competed in several meets.

The Betsy Schumacker Award, given annually to an undergraduate woman for excellence in athletic competition, will be received by Julia Neuringer '81. Neuringer led the Tech field hockey team to a 9-4-1 record in 1980, its best record in its four years on the varsity level. The Wellesley native scored a team-high 16 goals in 1980, and 34 in four years at MIT.

Faith Alexandre '81 is the 1981

winner of the Pewter Bowl award, for the female senior who has shown qualities of inspiration and leadership in women's athletics. Alexandre has been a four-year member of women's crew, earning her first varsity letter for her performance this spring.

Also receiving the Kispert award is Nancy Robinson '81. Robinson, according to Coach Eric Solle, is one of the best women fencers in MIT history. She won both the New England invitational and collegiate titles in foil, in addition to competition in the NIAW championships.

Other Award winners include:

Freshman Athlete-of-the-Year: Ken Shull (wrestling), Bob Schoenlein (swimming)

Straight "T's": Oscar Estell, Geoff Pingree, Nancy Robinson (Fencing), Ned Emerson (Golf), Sandy Young (Women's Gymnastics), John Schmitz, Bob Schoenlein (Swimming), Paul Neves (Track), Martin Serrine, Ray Swartz, Duncan Hughes, Jon Williams, John Blascovich, H. Thomas Sharp, Edward Seidman, and Spencer L. Webb (all Pistol)



An expectant IM softball player lines up in pre-game practice on a Briggs Field baseball diamond. See story this page. (Photo by Steve Cohen)

Final A and B league IM Volleyball standings

By Eric R. Fleming

The Baker Orangutangs, Rocksliders, and the Reducing Agents earned the spotlight this weekend, as these three teams won intramural softball titles.

The Orangutangs captured the A-League fast championship, on the strength of a 2-1 victory Saturday morning over MacGregor-In-Exile. A win by MacGregor would have forced a one-game playoff to determine the champion. Baker ends its season with a record of 5-1, while MacGregor finishes at 3-3.

The Reducing Agents, a group of Chemistry graduate students, won the B-League Championship with a come-from-behind 10-8 victory over Phi Beta Epsilon (PBE) (also last year's runner-up) in the first half of Sunday's championship doubleheader. The

Reducing Agents tallied four runs in the top of the seventh inning, and held off a PBE threat in the last half-inning to win.

Earth and Planetary Sciences' Rocksliders took the A Slow title, by defeating defending champ Sigma Alpha Epsilon (SAE). SAE gained a berth in the finals by beating the LIDS, 10-7 in nine innings, while the Rocksliders edged the Free Agents, 12-11, scoring four in their half of the seventh to earn the victory.

Again, the Rocksliders fought back from a deficit, and hung on in the late innings. The eventual winners came back from a 4-0 disadvantage to tie the contest at four at the end of three, and erupted for eight runs in the fourth to take a 12-5 lead. SAE scored thrice in the bottom of that inning, but could do no more, as the final score was 12-8.

Baker, EPS, and Chemistry teams are 1981 IM Softball champions

A-League		Alpha Deltas		0-6		Kuhli Lamas (Baker)		1-5	
The Brazilians	6-0					NTS B2			0-6
Koreans-A	4-2	Division 3				Division 6			
The PBRs (Baker)	4-2	Wallyball (EC)	6-0			Random	6-0		
TSD (Transportation)	3-3	TDC-B	5-1			Hydros	4-2		
Biology	3-3	Vertical Smiles II (Sr. House)	4-2			ATO B	4-2		
Desmond House	2-4	Number Six	2-4			NTS B1	4-2		
Kappa Sig A	1-5	Sig Ep B	2-4			Quaternaries	2-4		
A-League Champions: Brazilians		Rita and the Freshguys	1-5			PBE Smashers	1-5		
		Burton 5 Chain Smokers	1-5						
B-League Division 1		Division 4		Division 7					
F-Entry Vigilantes	6-0	AEPi B	6-0	Space Cadets (Space Systems Lab)	6-0				
Heimlich Maneuver (EC)	5-1	MIE	4-2	E. Snails	4-1				
Burton 4 Players B	4-2	Dynamics	3-3	Fred's VBall Team and Emporium (MacGregor)	3-2				
Kappa Sig B	2-4	Toaster Ovens	3-3	Decadence (PLP)	3-2				
Theta Xi Spikers	2-4	CTS	3-3	Snow White & the Seven Dwarfs (EC)	1-4				
Schlumps (PDT)	1-5	41st West	2-4	TEP	1-5				
Crazed Hips	1-5	The Wimpy Ones	0-6	Screw (Sr. House)	0-6				
Division 2		Division 5							
Atroti	6-0	Delts	6-0	B-League Champions: Random					
Beast From the East	4-2	Koreans B	5-1	Submitted by Rick Norton, Vol-					
Conner 45s	3-2	Chi Phi	4-2	leyball Manager					
C-Hawks B	2-3	Chelates I	4-2						
Theta Chi	2-4	Conner 3	2-4						
Club Latino	2-4								

sports update

Track — Coach Gordon Kelly's fine squad has done it again. Saturday, the mighty Engineers (4-1 in meet competition this spring) won the New England Division III outdoor championships held at Bowdoin. Coupled with the indoor title won at Bates in March, MIT becomes the first school ever to win both indoor and outdoor in New England Division III in the same season. As with all Tech track wins over the year, it was a total team effort that earned them the title.

Paul Neves '83, concluding an absolutely phenomenal year, won the 800 and 1500 meters to lead MIT. His 1500 time of 3:51.89 set a meet record. Dave Keida '81 won the hammer with a toss of 176 feet, 1 inch, and Martin Taylor '83 won the long jump (45-0) and took third in the high jump, and John Taylor '84 finished in the runnerup spot in the 400-meter hurdles. Tech won the meet with 75 points, with Fitchburg State and Westfield State (last year's defending

champs) tied for second, at 64 points each. The 1980-81 year has been MIT's finest in history, and credit must go to the coaches, Kelly and Clifton West, and of course, the athletes who have made MIT one of the best in New England. With minimal losses due to graduation, and a talented crop of freshmen returning for next year, look for the Engineers to be at or near the top in '81-82.

Season Summaries

Baseball — Doubleheader split with Tufts leaves Tech nine at 5-12 for spring. Strong pitching turned in by seniors George Noll and Carl Nowiszewski.

Golf — 10-6 for spring '81. Led by Ned Emerson '81 who will be in NCAA Div. III tourney May 18-19.

Lacrosse — Third straight winning season at 7-6. John "Legs" LaPlante '82 scores 38 goals to lead Tech. Adam Sapirstein concludes career as a top goalie (see awards story).

Softball — Late-season surge leaves squad at 7-8 for year.

Tough 18-17 loss to Endicott at home Thursday followed by 20-5 blowout win at Nichols. Frosh Liz Anderson sparkles for MIT in center. Group is a young one, year's experience can only help.

Men's Tennis — 6-7 record in Coach Ed Crocker's 25th year. Charlie Calkins '81 top player.

Women's Tennis — Lone victory in six tries 6-3 win over Bentley at MIT. Karen Haug '82, one of top MIT women players ever, not present with squad at start, but comes back at the end. Singles play of Sue Strausman '83 and Alison Kutchins '82 key to win over Bentley.

Crew — Tough year all around for heavies and lights, while women finished year strong with win at N.E. Invitational last week, and a pair of firsts (Varsity Lightweight eight, and Varsity Fours) at the EAWRC Sprints held in Lake Wasamaug, Connecticut, two days ago. Heavyweight men are 0-5 and lightweight men are 1-3 going into EARC's this coming weekend.

ATTENTION

Faculty and Staff

Preferred Rates Available
on
Homeowners Insurance

from
Horace Mann Insurance Co.

ENDORSED: NATIONAL EDUCATION ASSOC.
and
MASS. TEACHERS ASSOC.

SAMPLE RATE for NEEDHAM
(Deluxe Homeowners \$100 deductible)

Dwelling	50,000 - 255/yr
	75,000 - 400/yr
	100,000 - 547/yr

FOR DETAILS, CALL or WRITE:

Paul Gilman
24 Shuman Circle
Newton, MA 02159
Tel: 964-1095

Richard Bono
46 Pine Grove St.
Needham, MA 02194
Tel: 444-6280